



Volkswagen

# The Passat and Passat Estate



## Contents.

04	Design
08	Interior
14	Driver's assistance systems
16	Radio and navigation systems
24	Passat and Passat Estate S
26	Passat and Passat Estate BlueMotion
28	Passat and Passat Estate SE Business
30	Passat and Passat Estate GT
32	Passat Alltrack
34	Passat and Passat Estate R-Line
36	New Passat and Passat Estate GTE and GTE Advance
42	Alloy wheels
44	Think Blue
46	Paint
48	Upholstery
50	Combinations
56	Technical specification and Technology – Diesel
64	Technical specification and Technology – New GTE and GTE Advance
66	Dimensions
68	CO <sub>2</sub> emissions and VED bands with optional wheels
70	AdBlue®
74	Volkswagen service

Front cover models shown are Passat GT 2.0 BiTDI 240 PS 4MOTION and Passat Estate GT 2.0 BiTDI 240 PS 4MOTION with optional 19" 'Verona' alloy wheels and metallic paint.



Model shown is new Passat GTE with optional panoramic sunroof, LED premium headlights, Area view and premium signature paint.

Model shown is new Passat GTE Estate with optional LED premium headlights and premium signature paint.

---

# The Passat. Refined, advanced, elegant.

Charismatic and sophisticated, the Passat and Passat Estate just exudes confidence. Making its appearance as the eighth generation of a best-selling car that has sold nearly 22 million models since 1973, the Passat features advanced technologies and sophisticated assistance systems, providing new levels of comfort, luxury and performance than its predecessors. And that's not all. With its cutting-edge design, technologies and engines, the Passat and Passat Estate are as versatile, progressive and sophisticated as you could wish for.



Model shown is Passat GT 2.0 BiTDI 240 PS 4MOTION with optional 19" 'Verona' alloy wheels and metallic paint.



Model shown is Passat Estate GT 2.0 BiTDI 240 PS 4MOTION with optional 19" 'Verona' alloy wheels and metallic paint.

---

## The shape of success.

Engineering and design are raised to a new level in the latest generation Passat and Passat Estate. Sharp styling includes a longer wheelbase, shorter body overhangs and a dynamic silhouette with distinctive tornado line, accented by trapezoidal headlights and rear lights, creating an imposing road presence. The redesigned interior complements the sophisticated exterior, with a host of equipment and advanced features providing sublime levels of comfort and convenience. Inside and out, this is functionality at its most stunning: sleek, stylish and dynamic.



Interior shown is Passat Estate GT DSG with optional smoking pack, net partition and metallic paint.

---

## Sitting comfortably? Then your journey can begin.

However long or short your journey, you'll always sit comfortably in the Passat. Stylish, durable and ergonomically designed to provide optimum comfort and support, seats are available in a range of contemporary upholsteries and leathers. Standard front seats provide manual height and lumbar adjustment, while SE Business models and above feature ergoComfort front seat for the driver, providing lumbar support, seat cushion tilt adjustment, thigh support and electric backrest adjustment, enabling you to find the most comfortable position for your spine easily and quickly. With the spacious interior providing more head and legroom than ever before in a Passat model, there's plenty of room for family, friends and equipment, especially in the Passat Estate. School run, weekend away or driving to work, driving is so easy and relaxed.

# More space. More versatility. More possibilities.

Whether you're taking a business trip or going on a major shopping expedition, the Passat and Passat Estate are designed to meet your everyday needs. The variable boot floor is height adjustable and removable, providing plenty of room for your equipment or purchases. While the optional keyless entry includes hands-free boot or tailgate opening, which opens the boot or tailgate remotely, ideal if your hands are full. In the Passat Estate, the load volume increases to a massive 1,780 litres<sup>1</sup> with the back seats folded down, providing a surprising amount of load space. Versatile, flexible and more spacious than ever before, you can rely on the Passat to help keep you organised.

<sup>1</sup> Please see page 66 for full details of dimensions.



**01** Integrated child seats<sup>2</sup> are convenient, practical and easy to use, available for children weighing 15 – 36kg and up to 1.5m tall. Designed to provide optimal side support, they provide a bespoke solution for carrying small occupants. Optional on all models except GTE and GTE Advance. Image shown features optional 'Nappa' leather.

**02–04** To extend the boot space, simply release the rear seat backrest either from the boot or the rear seat. The **variable boot floor** helps facilitate loading and unloading, while the optional cargo management system<sup>3</sup> or optional luggage compartment divider pack<sup>3</sup> helps keep luggage secure in transit. Cargo management system and luggage compartment divider pack are optional on all estate models except GTE and GTE Advance.

<sup>2</sup> Integrated child seats are only available on standard Titan Black upholstery or optional Titan Black leather upholstery.

<sup>3</sup> Luggage compartment divider pack and cargo management system are not available in conjunction with each other.



Interior shown is Passat Estate GT with optional net partition and metallic paint.

---

# Bring the outside in.

Enjoy the sky above like never before thanks to the Passat's panoramic sunroof. Creating a well-lit, airy passenger compartment, it lets in fresh air and natural light, and in the Passat Estate, an additional panoramic sunroof to the rear provides even more light and space. What better way to enjoy a starry night or sunlit day?

Panoramic sunroof is standard on GT, R-Line and GTE Advance and optional on all other models.



Interior shown is Passat Estate GT with optional net partition and metallic paint.

# The intelligent way to drive.

With numerous driving assistants to help share the workload, the Passat provides on-board help should you need it. Smart, intelligent and capable, this is a car made for sophisticated drivers who delight in innovative technology.

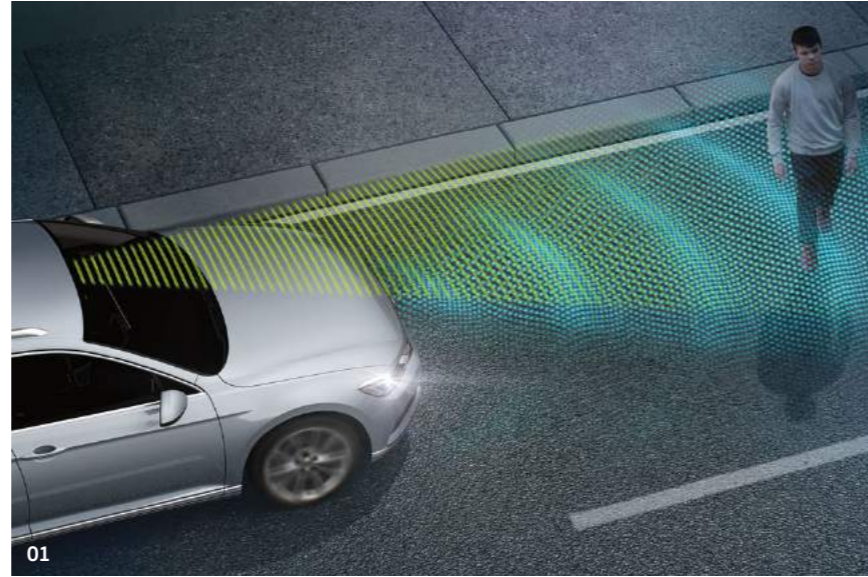

**01 Predictive Pedestrian Protection**, part of the optional Driver's Assistance Pack and Driver's Assistance Pack Plus, warns you if it detects, in addition to vehicles, any pedestrians at the edge of the road or on the carriageway via acoustic and optical signals as well as a gentle jolt of the brakes. It even performs an emergency stop should the distance become critical, helping to protect you not only from other road users, but potential accidents. Optional on SE Business models and above. Model shown features optional metallic paint.

**02 Trailer Assist including Park Assist**. Anyone who has tried to manoeuvre a vehicle with a trailer attached understands how complicated this can be. The world's first Trailer Assist helps you reverse with a trailer attached more easily and accurately. The optical display visualises actual and possible steering angles in the instrument cluster. Reverse steering is automatic, with direction controlled via the mirror adjustment switch which acts as a joystick, while the driver controls the pedals and keeps a good look out. Optional on SE Business models and above. Only in conjunction with the optional swivelling towbar. Model shown features optional metallic paint.

**03 Traffic Jam Assist** helps take some of the stress out of driving in congested traffic by maintaining a constant distance from the vehicle in front, preventing you from having to continually stop and start in slow moving traffic. The camera and radar sensor controlled system accelerates, brakes and even steers should the vehicle drift out of its lane, providing the driver maintains hold of the steering wheel. Not only does it help avoid nose-to-tail collisions, it also helps guide you through narrow sections and tight roadwork lanes. Optional on SE Business models and above in conjunction with DSG gearbox only. Traffic Jam Assist is part of the optional Driver's Assistance Pack Plus. Must be ordered in conjunction with optional LED premium headlights. Model shown features optional metallic paint.



**04 Area view**. Four cameras located in the boot lid/tailgate, door mirrors and radiator grille, each with an aperture angle of over 180 degrees, provides a 360-degree view around the Passat helping you manoeuvre in confidence in any direction. From the display menu, the driver can select the camera views; front, rear, side or bird's-eye view, on either full or split-screen, displayed on the Passat's infotainment system. Standard on GTE Advance and optional on SE Business models and above. Not in conjunction with rear-view camera. Model shown features optional metallic paint.



**05 – 06 The Active Info Display<sup>1</sup>**. Ideal for those who love the latest technology, providing a system that can be tailored to suit your specific preferences. A fully configurable, interactive, 12.3 inch high resolution TFT dash display replaces the standard instrument cluster, displaying vehicle data and information on your dashboard. A choice of five different modes enables you to customise the screen as you wish, showing large or small dials as you prefer, with a number of items displayed behind. In navigation mode, for example, you can move the speedometer and rev counter to the edge of the display, creating more space for the navigational map. If you wish, you can include driving, navigation and assistance functions within the graphics of the speedometer. As the Active Info Display is linked to all other assistance systems in the vehicle, any data shown in the centre console of the infotainment system, such as phone numbers or compatible cover art, can also be displayed on the dash, conveniently placed directly within the driver's optimum field of vision. Standard on GT, R-Line and GTE Advance and optional on SE Business, GTE and Alltrack models.



**07 Head-up Display<sup>2</sup>**. At the press of a button, the transparent display rises from its position behind the dashboard into the driver's primary field of vision. Driving information including current speed is projected onto the retractable screen, helping to reduce the time that the driver's eyes are averted from the road. Optional on SE Business models and above. Model shown features Adaptive Cruise Control (ACC).



<sup>1</sup> Not in conjunction with multifunction colour display. Must be ordered in conjunction with 3Zone electronic air conditioning on SE Business models.  
<sup>2</sup> Only available in conjunction with LED or LED premium headlights. Must be ordered in conjunction with multifunction colour display or Active Info Display and 3Zone electronic air conditioning on SE Business models. Please note, use of polarised lenses may impair the visibility of the Head-up Display.

Please refer to your Volkswagen owner's manual for information on system parameters and official guidance on use and operation of all our technology. Images shown are for illustration purposes only and may not necessarily reflect UK specification.



# Advanced acoustics. State-of-the-art navigation.



**01** The **Composition Media system** is equipped with a 6.5 inch colour touch-screen with proximity sensor that recognises in advance your intention to touch the screen and automatically magnifies the display mode. Features also include DAB digital radio receiver, single CD player, MDI (Multi Device Interface) via USB connection for compatible products and SD card reader. The media system also includes Bluetooth telephone and audio connection for compatible devices<sup>1</sup>, simultaneous pairing of 2 compatible mobile devices, SMS functionality – allowing you to read, compose and send SMS messages using the touch-screen display to a compatible Android smartphone (while the vehicle is stationary), title and compatible cover art display and facilitates music playback from MP3, WMA and AAC files through eight speakers, front and rear. Finally, car information display and 'Think Blue. Trainer.' – provide journey analysis and driver tips on your journey. Standard on S and BlueMotion models.

<sup>1</sup> Devices must be Bluetooth HFP (Hands Free Profile) compatible, please contact your authorised Volkswagen retailer for specific device compatibility.



**02** The **Discover Navigation touch-screen navigation/radio system with Car-Net 'Guide and Inform'**<sup>2</sup> builds upon the impressive Composition Media system, but with additional features enabling you to easily manage not only your music, but also navigation data and a broad range of vehicle information. The system offers preloaded European navigation data, 2D/3D map view, three calculated route choices (Fast, Short and Eco), dynamic navigation based on TMC+, branded points of interest and Speed Limit Display<sup>3</sup>. 3-year's Car-Net 'Guide and Inform' access makes it possible to integrate 'traffic information online' into route guidance and transfer public and personal points of interest to the navigation system. The service also includes information for fuel location and pricing, parking space availability, weather and news feeds. Standard on SE Business, GT, Alltrack, R-Line and GTE models. Optional on S and BlueMotion models.

<sup>2</sup> Car-Net 'Guide and Inform' services are accessed via a compatible mobile device. Please see [www.volkswagen.co.uk](http://www.volkswagen.co.uk) for more information. The use of 'Guide and Inform' services entails exchanging large volumes of data. As such, we strongly recommend that you sign-up for a flat rate data plan with your mobile network provider. After the initial 3-year Car-Net contract, an annual subscription is chargeable for the continuation of Car-Net 'Guide and Inform' services.

<sup>3</sup> Speed Limit Display only reflects national speed limits and does not show temporary speed limit restrictions, or where permanent changes to speed limits are made in-between map updates.

**03** The **Discover Navigation Pro touch-screen navigation/DVD radio system with integrated voice activation, Car-Net 'Guide and Inform Plus'**<sup>2</sup> and Car-Net 'App-Connect' can be operated intuitively via the 8.0 inch TFT colour touch-screen, enabling you to manage music and navigation data. Eight powerful speakers deliver great acoustics and the DVD system is compatible with MP3 and WMA files. It also offers a 64 GB SSD hard drive, two SD card readers, photo display from JPEG and PNG files, voice control and a USB connection. The Discover Navigation Pro also features 'Guide and Inform Plus' providing online access to a range of useful information such as traffic, fuel pricing, parking space availability, weather, news feeds and Google Earth. In addition, the Car-Net 'App-Connect' combines the functionality of Apple 'CarPlay', Google 'Android Auto' and 'MirrorLink'<sup>™</sup> allowing 'mirroring' of a smartphone display on the infotainment touch-screen via USB connection. Display and operation of certified apps including audio and voice control (if supported by the app). Usage of certified apps only while driving. Only operable in conjunction with compatible smartphones including iPhone 5, 6 and 7. Please see [www.volkswagen.co.uk](http://www.volkswagen.co.uk) to check smartphone compatibility. Standard on GTE Advance and optional on all other models.



Interior shown is Passat GT with optional Discover Navigation Pro touch-screen navigation/DVD radio system.

# Concert hall sound. Living room comfort.



**01** The **multifunction leather trimmed steering wheel** enables you to operate the radio and phone without taking your hands off the wheel, and GT models and above are equipped with automatic DSG transmission, feature paddle shift. A heated steering wheel is optionally available on SE Business<sup>1</sup>, GT and Alltrack<sup>1</sup> models. On warm days, **climate control – 3Zone electronic air conditioning** with automatic air recirculation ensures a pleasant interior temperature to suit the individual preference of driver, front and rear seat passengers. Optional on SE Business models. Standard on GT models and above. Model shown is Passat GT with optional Discover Navigation Pro touch-screen navigation/DVD radio system.

**02** The **'Dynaudio Confidence'** sound system provides enhanced acoustics via a ten channel digital amplifier, delivering 700 watts output through ten speakers optimally located around the cabin to ensure unique sound quality for every occupant. Optional on SE Business models and above.

<sup>1</sup> Must be ordered in conjunction with Winter pack or leather upholstery.



Interior shown is Passat GT with optional 'Dynaudio Confidence' soundpack and metallic paint.



Interior shown is Passat GT DSG with optional Discover Navigation Pro touch-screen navigation/DVD radio system with integrated voice activation, Car-Net 'Guide and Inform Plus' and Car-Net 'App-Connect'.

## Car-Net. The smart way to stay connected.



02 Whether you are using a phone, radio or radio/navigation system, **Voice activation** allows you to control everything by spoken command. Available commands are shown on the screen, and your chosen text is highlighted in red. After activation, a red symbol indicates that the instruction has been accepted. Standard on GTE Advance and optional on all other models. Voice activation is standard on Discover Navigation Pro touch-screen navigation/DVD radio systems.



03 The **Car-Net 'App-Connect'** combines functionality of Apple 'CarPlay', Google 'Android Auto' and 'MirrorLink™' allowing 'mirroring' of a smartphone display on the infotainment touch-screen via USB connection. Only operable in conjunction with compatible smartphones including iPhone 5, 6 and 7. **Volkswagen apps** such as 'Think Blue Trainer', 'Shared Audio', 'Drive & Track' or 'My Guide' can help to make your journey more pleasant and interesting, providing useful tips about handling your car, parking opportunities and even where to find the closest café. Volkswagen apps are only available with compatible smartphones. Please consult [www.volkswagen.co.uk](http://www.volkswagen.co.uk) to check smartphone compatibility. Usage of certified apps only while driving. Standard on GTE Advance and optional on all other models. Car-Net 'App-Connect' is included with the optional Discover Navigation Pro touch-screen navigation/DVD radio system. Discover Navigation Pro radio system is standard on GTE Advance models.

01 With Car-Net 'Guide and Inform'<sup>1</sup> your Passat becomes a mobile network using your smartphone's WIFI hotspot. You can access up-to-the-minute information directly from the internet, enabling you to benefit from continually updated information while you travel, such as online traffic information, fuel pricing, parking space availability, weather and news feeds. Car-Net 'Guide and Inform' includes online navigation software updates, enabling you to download the latest map data. 3-year's Car-Net 'Guide and Inform' access is standard on SE Business models and above, and included with optional navigation systems for S and BlueMotion models. Please contact your authorised Volkswagen retailer for full details.

Opting for the Discover Navigation Pro touch-screen navigation/DVD radio system means that you can benefit from even more features such as Google Earth and more with 'Guide and Inform Plus'<sup>1</sup>. Standard on GTE Advance and optional on all other models.

<sup>1</sup> Car-Net 'Guide and Inform' and 'Guide and Inform Plus' services are accessed via a compatible mobile device. Please see [www.volkswagen.co.uk](http://www.volkswagen.co.uk) for more information. The use of all 'Guide and Inform' services entails exchanging large volumes of data. As such, we strongly recommend that you sign-up for a flat rate data plan with your mobile network provider. After the initial 3-year Car-Net contract, an annual subscription is chargeable for the continuation of all 'Guide and Inform' services.

---

# Business or personal, practical or sporty, the choice is yours.

Versatile and adaptable, the Passat and Passat Estate has room for your passengers, luggage and more. Depending on your requirements, eight models are available: the S, BlueMotion, SE Business, GT, Alltrack, R-Line, GTE and GTE Advance, each offering varying levels of trim, ranging from practical and elegant to luxurious and sporty. Whichever you select, you'll benefit from a host of advanced features and refinements.



Model shown is Passat SE Business with optional LED premium headlights and metallic paint.

## Passat and Passat Estate S.

The Passat S models are equipped with a whole range of innovative assistance systems fitted as standard, helping to ensure the highest levels of comfort, practicality and convenience. Inside, the interior is fitted with stylish 'Hampshire' cloth upholstery, front seats with lumbar adjustment, a leather trimmed three-spoke multifunction steering wheel and gear knob, and 'Brushed chrome' decorative inserts in the dash, centre console and door panels. Chrome-plated instrument and air vent surrounds, interior lighting with a delay and dimming function create a pleasant ambience, while the 60:40 split folding rear seat backrests (40:20:40 on Estate models) offer greater flexibility when carrying luggage or loads, especially in the Passat Estate.

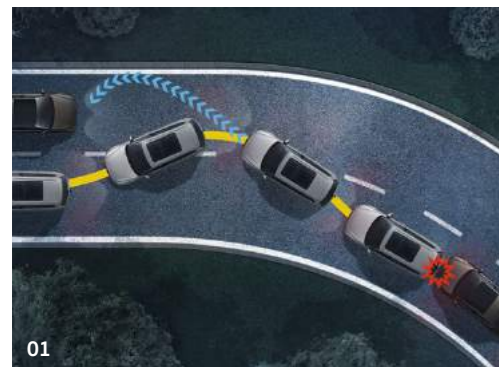

**01 Automatic Post-Collision Braking System** starts the brake operation after an initial impact, and brakes for as long as necessary to reduce the speed of the vehicle to help prevent or minimise further collisions. Image shown is for illustration purposes only and may not necessarily reflect UK specification.

**02 Press and drive (Keyless start)** enables you to start the engine using a button in the centre console, without taking the key from your pocket.

**03 16 inch 'Aragon' alloy wheels** with 215/60 R16 low rolling resistance tyres add a touch of refinement to the exterior of the Passat S.

**04 The Composition Media system** with 6.5 inch colour touch-screen display, DAB digital radio, Bluetooth telephone and audio connection<sup>1</sup>, MDI (Multi Device Interface) via USB connection from a compatible device, SD card reader, single CD player and 'Think Blue. Trainer.' with driver tips and journey analysis.

<sup>1</sup> Devices must be Bluetooth HFP (Hands Free Profile) compatible, please contact your authorised Volkswagen retailer for specific phone compatibility.



Interior shown is Passat S DSG with optional metallic paint.

## Passat and Passat Estate BlueMotion.



Interior shown is Passat BlueMotion with optional metallic paint.

The Passat Saloon and Estate BlueMotion models are equipped with lowered sports suspension, lowering the body by approximately 15mm. Along with the restyled radiator grille with blue strip, air resistance is reduced which improves the aerodynamics of the BlueMotion models and helps to improve roadholding. The weight-saving innovative lightweight construction and refined gearbox transmission with longer gear ratios and features such as the Start/Stop function that saves fuel when the vehicle is stationary, battery regeneration (recuperation – energy recovery during braking), and visual gear change recommendation also help to make the BlueMotion the most efficient model in the Passat range.

The BlueMotion Passat returns 76.3mpg<sup>1</sup> on the Combined Cycle with CO<sub>2</sub> emissions of 95g/km<sup>1</sup>, and performance is not compromised either. The Saloon model accelerates from 0-62mph in just 10.8 seconds on its way to a top speed of 130mph where the law permits, while Estate models boast a respectable 0-62mph in 11.0 seconds and a top speed of 129mph where the law permits.

As well as the performance, the Passat Saloon and Estate BlueMotion offer great levels of comfort and refinement. Features including 17 inch 'Soho' alloy wheels, uniquely shaped BlueMotion front and rear bumpers, a chrome trimmed front air intake and radiator grille with blue strip, lowered sports suspension and distinctive 'BlueMotion' badging, create an exterior that is more aerodynamic than other Passat models, yet still sporty and exciting.

<sup>1</sup> Fuel consumption figures in mpg/ltr per 100km; Urban (65.7/4.3); Extra Urban (85.6/3.3); Combined (76.3/3.7) and CO<sub>2</sub> emissions 95g/km are obtained under standardised EU test conditions (Directive 93/116/EEC). This allows a direct comparison between different manufacturer models but may not represent the actual fuel consumption achieved in 'real world' driving conditions. Please see pages 58-61 for full details. More information is available on the Volkswagen website at [www.volkswagen.co.uk](http://www.volkswagen.co.uk) and at [www.dft.gov.uk/vca](http://www.dft.gov.uk/vca).



01



02

**01** The unique **BlueMotion badge** identifies the most economical model in the Passat range. The distinctive 'BlueMotion' badging adorns the front, back and sides of these very special Passat models.

**02** 17 inch 'Soho' alloy wheels with 215/55 R17 tyres add style and charisma to the exterior of the Passat BlueMotion.



Model shown is Passat BlueMotion with optional 17" 'Istanbul' alloy wheels, LED premium headlights, Convenience pack and metallic paint.



Interior shown is Passat SE Business with optional Discover Navigation Pro touch-screen navigation/DVD radio system with integrated voice activation, multifunction colour display, climate control – 3Zone electronic air conditioning, 'Vienna' leather upholstery and metallic paint.

## Passat and Passat Estate SE Business.

The well-appointed Passat SE Business models build on the S level specification with impressive levels of comfort and practicality and many advanced features. The refined interior is beautifully equipped with 'Kensington' cloth upholstery, an ergoComfort driver's seat with electric backrest and seat cushion tilt adjustment and front passenger's seat with height and lumbar adjustment. Front and rear carpet mats, 'Diamond Silver' decorative inserts in the dash, centre console and door panels, and LED entrance/warning lights in the front doors add further elegance, while two covered cup holders in the front and a load-through provision provide practical extra touches. The latest version of the Driver profile selection takes the Passats to a new level of comfort and relaxation. This driver assistance system brings together numerous settings, allowing you to set the perfect and optimal position, and personalise settings for items such as wing mirrors, map and route settings, radio stations, air conditioning, central locking, windows and interior lighting.

The exterior of the Passat SE Business models are equipped with an even higher levels of specification, such as front fog lights, rear tinted glass from the B pillar backwards, approximately 65% tinted and remote electrically foldable door mirrors, door mirror puddle lights and reverse activated kerb-view adjustment on the passenger's side. While inside, the latest Discover Navigation system with 3 years Car-Net 'Guide and Inform'<sup>1</sup> internet access provides a range of information, including traffic, fuel pricing, parking space availability, weather and news feeds.



**01** The Discover Navigation touch-screen navigation/radio system with Car-Net 'Guide and Inform'<sup>1</sup> offers preloaded European navigation data, 2D/3D map view, three calculated route choices (Fast, Short and Eco), dynamic navigation based on TMC+, branded points of interest and Speed Limit Display<sup>2</sup>. 3-year's Car-Net 'Guide and Inform' access makes it possible to integrate 'traffic information online' into route guidance and transfer public and personal points of interest to the navigation system. The service also includes information for fuel pricing, parking space availability, weather and news feeds.



**02** Adaptive Cruise Control (ACC), including Front Assist radar sensor controlled distance monitoring system, City emergency braking system, cruise control and speed limiter offers you intelligent control of your driving speed by automatically adjusting acceleration and braking. Whether around town or on the motorway, the system will adjust your speed to that of the vehicle in front, keep your specified distance, warn if you are approaching too fast and, in an emergency situation, generate enough braking force to try to reduce the severity of a collision or possibly even prevent the collision entirely. Image shown is for illustration purposes only and may not necessarily reflect UK specification.



**03** 17 inch 'London' alloy wheels with 215/55 R17 self-sealing tyres add a further touch of elegance.

**04** Rear tinted glass from the B pillar backwards is approximately 65% tinted, helping to keep the interior cooler in direct sunlight and creating an executive presence. Model shown features optional metallic paint.

<sup>1</sup> Car-Net 'Guide and Inform' services are accessed via a compatible mobile device. Please see [www.volkswagen.co.uk](http://www.volkswagen.co.uk) for more information. The use of 'Guide and Inform' services entails exchanging large volumes of data. As such, we strongly recommend that you sign-up for a flat rate data plan with your mobile network provider. After the initial 3-year Car-Net contract, an annual subscription is chargeable for the continuation of Car-Net 'Guide and Inform' services.  
<sup>2</sup> Speed Limit Display only reflects national speed limits and does not show temporary speed limit restrictions, or where permanent changes to speed limits are made in-between map updates.



Interior shown is Passat GT DSG with optional Discover Navigation Pro touch-screen navigation/DVD radio system with integrated voice activation, smoking pack and metallic paint.

## Passat and Passat Estate GT.



The Passat and Passat Estate GT models exude exclusivity, which is shown in the attention to detail and craftsmanship. Inside, luxurious seats feature Alcantara seat centre section and 'Vienna' leather<sup>1</sup> side bolsters, while brushed aluminium decorative inserts in the dash and door panels, 'Piano Black' decorative inserts in the centre console and ambient lighting create elegance and style. Other luxurious features include climate control – 3Zone electronic air conditioning with automatic air recirculation, Discover Navigation system with 3 years' access to Car-Net 'Guide and Inform'<sup>2</sup>, panoramic sunroof, remote electrically foldable door mirrors, door mirror puddle lights and reverse activated kerb-view adjustment on the passenger's side and heated windscreen washer jets.

**01** The innovative **Active Info Display** ingeniously displays all instrumentation in a fully interactive virtual format, with high quality graphics on a large 12.3 inch screen. As required, important data relating to driving can be pulled up directly within the driver's field of view and configured in an individually selected display. This includes 2D and 3D navigation information, driver assistance systems, driving information and details from the infotainment system, such as phone contacts or music album covers. For example, in 'navigation' mode, the speedometer and rev counter can be relocated to the sides to make more room for the map display.

**02** The **Passat GT 2.0 litre BiTDI 240 PS 4MOTION** features a number of refinements, including Dynamic Chassis Control (DCC) providing a choice of Sport, Comfort and Normal settings and XDS electronic differential lock for improved traction and handling. LED premium headlights with projection technology look sensational and include signature dual 'U-shaped' LED daytime running lights, 12 separate LEDs performing the indicator function, dynamic curve lighting and headlight washers to help keep them clean. Stylish trapezoid exhaust tailpipes left and right, complete the look to the rear. Model shown features optional metallic paint.

**03** **Heated front seats** add luxury and comfort in the cold weather, giving the interior an especially warm and welcome feel in winter.

**04** 18 inch '**Oxford Anthracite**' alloy wheels with 235/45 R18 self-sealing tyres are eye-catching and sporty.



<sup>1</sup> Some parts of leather interior will contain artificial leather.

<sup>2</sup> Car-Net 'Guide and Inform' services are accessed via a compatible mobile device. Please see [www.volkswagen.co.uk](http://www.volkswagen.co.uk) for more information. The use of 'Guide and Inform' services entails exchanging large volumes of data. As such, we strongly recommend that you sign-up for a flat rate data plan with your mobile network provider. After the initial 3-year Car-Net contract, an annual subscription is chargeable for the continuation of Car-Net 'Guide and Inform' services.



## Passat Alltrack.

The Passat Alltrack is designed to take you off the beaten track. Great off-road performance provides all-terrain capability, from smooth and inclined to rough and rugged, allowing every day to become an adventure should you choose. Its 4MOTION four wheel drive combines with off-road suspension providing up to 27.5mm increased ground clearance compared to standard models and an 'Off-road' setting with hill descent assist to deliver true off-road driving characteristics.

Externally, the 'Alltrack' styling pack is designed to impress with uniquely shaped off-road front and rear bumpers, a chrome trimmed radiator grille and front air intake, matt-chrome effect door mirrors, trapezoid exhaust tailpipes and unique 'Alltrack' badging. Meanwhile, prominent anthracite wheel arch protection, matt-chrome effect and anthracite side sill protection, matt-chrome effect underbody protection at the front and rear, and sporty 18 inch 'Kalamata' alloys wheels ensure this is a car that's built for action.

Front fog lights with static cornering, rear tinted glass from the B pillar backwards approximately 65% tinted, silver anodised roof rails and rear lights with LED technology complete the look, delivering the ultimate in off-road style.

A wealth of interior refinements will help you travel in comfort and style, whatever the terrain. Reflecting the Passat Alltrack's off-road character are such details as stylish 'Summit' cloth upholstery, 'Tracks' decorative inserts in the dash, centre console and door panels, brushed stainless steel pedals and door sill protectors with the unique 'Alltrack' logo.

3Zone electronic climate control with automatic air recirculation enables you and your passengers to choose their preferred interior temperature, while a multifunction colour display, ambient lighting, heated windscreen washer jets, remote electrically foldable door mirrors, door mirror puddle lights and reverse activated kerb-view adjustment on the passenger's side, provide the highest levels of interior quality. Quite literally, it's the full package and more.



01

**01** 18 inch 'Kalamata' alloy wheels, anthracite wheel arch protection and raised off-road suspension providing increased ground clearance adds to its off-road driving capability. Model shown features optional metallic paint.

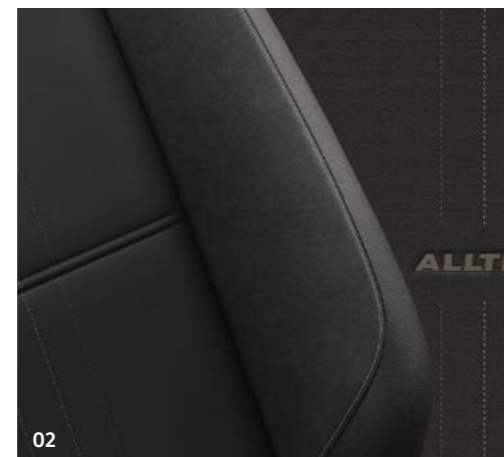

02

**02** The interior of the Alltrack is upholstered in robust 'Summit' cloth upholstery in Titan Black featuring the 'Alltrack' logo in the centre section.



Model shown is Passat Alltrack with optional 19" 'Albertville' alloy wheels, panoramic sunroof, LED premium headlights and metallic paint.

## Passat and Passat Estate R-Line.

Sporty, stylish and dynamic, the Passat R-Line models have an equally impressive specification with enhanced body styling and a number of additional features, delivering great levels of functionality, comfort and performance. The exterior of the R-Line is unmistakable with its distinctive 'R-Line' styling pack consisting of front and rear bumpers, radiator grille and side skirts. Front fog lights with static cornering function and chrome decorative trim and 18 inch 'Monterrey' alloy wheels complete the elegant, agile look. For those seeking the ultimate R-Line experience, the Passat Saloon R-Line 2.0 litre BiTDI 240 PS 4MOTION can accelerate from standstill to 62mph in a respectable 6.1 seconds on its way to a top speed of 149mph, where the law permits. Combine that with a number of additional refinements, including Dynamic Chassis Control (DCC) providing a choice of Sport, Comfort and Normal settings, LED premium headlights with projection technology, dual 'U-shaped' LED daytime running lights, 12 separate LEDs which perform the indicator function, dynamic curve lighting, headlight washers, and XDS electronic differential lock for improved traction and handling and you can't fail to be impressed.

Elegant and eye-catching, the Passat R-Line is designed to be different. The driver's ergoComfort seat and passenger's front seat feature 'Race' seat centre section and 'Vienna' leather<sup>1</sup> side bolsters, creating a luxurious and inviting interior, with the distinctive 'R-Line' logo on the backrests, echoing the 'R-Line' logo displayed on the leather trimmed three-spoke multifunction steering wheel with aluminium inserts, stainless steel pedals and matching unique 'R-Line' carpet mats, decorative inserts and door sill protectors. Finally, the electric panoramic sunroof with integrated roller blind adds a new dimension of fresh air and light to every trip, offering stunning views of the skies above from every seat. Driving has never been more fun.



Interior shown is Passat R-Line DSG 2.0 BiTDI 240 PS 4MOTION with optional Discover Navigation Pro touch-screen navigation/DVD radio system with integrated voice activation and Pure White non-metallic paint.



01 The innovative **Active Info Display** ingeniously displays all instrumentation in a fully interactive virtual format, with high quality graphics on a large 12.3 inch screen.



02 18 inch '**Monterrey**' alloy wheels with 235/45 R18 self-sealing tyres give the exterior of the R-Line its unique identity.

<sup>1</sup> Some parts of leather interior will contain artificial leather.



Model shown is Passat Estate R-Line 2.0 BiTDI 240 PS 4MOTION with optional 19" 'Verona' alloy wheels and Pure White non-metallic paint.



Model shown is new Passat GTE with optional LED premium headlights, panoramic sunroof and premium signature paint.

## New Passat and Passat Estate GTE.

Sleek, stylish and responsive, the new Passat and Passat Estate GTE are plug-in hybrids that offer the best of both worlds, combining a TSI petrol engine and electric motor to deliver a whole new driving experience. With front wheel drive and a specially developed six speed automatic DSG transmission fitted as standard, in 'GTE' mode it has the capability to accelerate Saloon models from 0-62mph in 7.4 seconds and Estate models in 7.6 seconds, on its way to a top speed of 140 mph where the law permits.

Externally, the Passat GTE displays its own inimitable style with a blue strip extending across the radiator grille into the range adjustable LED headlights and finishing neatly above the LED indicators. The blue theme continues on the 'GTE' badging on the radiator grille, front side panels and rear tailgate, while the sporty bumper features distinctive fins and characteristic 'C' signature LED daytime running lights that distinguish these models from the rest of the Passat range. 18 inch 'Oxford Anthracite' alloy wheels with striking 'Blue' brake callipers give real road presence, while the distinctive rear design features trapezoid exhaust tailpipes left and right, LED rear light clusters with dynamic lighting effect and rear number plate lights also incorporating LED technology.



**01** Passat GTE models are equipped with **two charging cables** with different plugs: one to charge up from a domestic mains socket, and one for a charging station or wall box. A wall box provides you with higher charging performance and consequently shorter charging time than a domestic mains socket. Using the standard mains charging cable, the Passat GTE recharges the high-voltage battery from a household socket in approximately 4 hours 15 minutes. Charging via a wall box or at a public charging station it's even faster; taking approximately 2 hours 30 minutes.

For information on wall box purchase and installation, local infrastructure check, servicing and customer helpline, please refer to your authorised Volkswagen retailer at point of sale. Wall box is not included. Wall box shown is for illustration purposes only.



**02** As a plug-in hybrid, the new Passat GTE could not be easier to use, with a petrol cap on the side and a charging point inlet cleverly positioned on the radiator grille. It offers **four driving modes**, including e-mode, Hybrid, Battery charge and 'GTE'. The operating mode selected, along with the energy flow and load condition of the lithium-ion battery are clearly displayed on the infotainment touch-screen display, with kinetic energy normally lost during braking converted to electricity by regenerative braking and fed directly to the battery where it is stored.

Image shown is for illustration purposes only.



**03** Volkswagen's **Car-Net e-remote mobile services app** allows you to access many vehicle functions remotely via your compatible smartphone. For example, you can activate your new Passat and Passat Estate GTE's air conditioning before your journey begins, ensuring a pleasant interior cabin temperature when you set off. You can control charging from a distance, starting and stopping remotely when you wish, with both the charging level and remaining range displayed on your compatible smartphone. You can also view information about your driving characteristics and journey, including average speed and journey time, and the app will even inform you whether the lights are still on and if the doors are locked, along with your last parking position, all from the comfort of your home or office. In addition, all functions can be easily controlled via the web portal at [www.volkswagen-carnet.com/uk](http://www.volkswagen-carnet.com/uk)



To find out more about the benefits of owning an ultra low emission vehicle, including the Government's grants for vehicles and chargepoints, visit [www.GoUltraLow.com](http://www.GoUltraLow.com)

Inside, the new Passat and Passat Estate GTE are every inch the sports performers, with the characteristic blue theme symbolising Volkswagen's e-mobility and setting the scene. Standard features include 'Blue' ambient lighting, a leather trimmed multifunction steering wheel and 'GTE' gear knob with blue contrast stitching, and heated front seats finished in stylish Alcantara with 'Vienna' leather<sup>1</sup> side bolsters. 'Aluminium Wave' decorative inserts in the dash and door panels, carpet mats front and rear, and the unique 'GTE' instrument cluster add luxury and style, all combining to give that unmistakable GTE feel.

Extra touches include 3Zone electronic air conditioning, an automatically dimming interior rear-view mirror, coming/leaving home lighting function, illuminated vanity mirrors, rain sensor and heated windscreen washer jets. Driver assistance systems include Adaptive Cruise Control (ACC) with Front Assist distance monitoring and City emergency braking which combine to provide reassurance and make every journey just that little bit easier.



**01** 18 inch 'Oxford Anthracite' alloy wheels with 235/45 R18 self-sealing tyres also feature 'Blue' brake callipers, co-ordinating perfectly with the unique 'GTE' radiator grille with blue strip and unique 'GTE' badging.



**02** The **Driver profile selection** includes 'GTE' mode, which activates its sportier side. At the touch of the GTE button, the electric and petrol motors combine to deliver 218 PS and a top speed of 140mph where the law permits. The steering wheel also becomes more responsive and the chassis firms up, the DSG gearbox changes gear quicker, keeping in the lower gears ready to accelerate on demand.



**03** At the press of a button next to the gear lever, the driver can select e-mode. **All-electric e-mode** is ideal for urban driving, providing near silent, emission-free operation when driving in town or residential areas up to a distance of 31 miles<sup>2</sup>. The Passat GTE will automatically start in 'e-mode' for greater efficiency, but should the battery have insufficient charge, or in cases of extreme low temperature, the GTE's TSI petrol engine will cleverly take over.



Interior shown is new Passat GTE DSG with optional Side scan and premium signature paint.

<sup>1</sup> Some parts of leather interior will contain artificial leather.

<sup>2</sup> Please see page 64 for CO<sub>2</sub> emissions and fuel consumption figures. Figures based on a fully charged battery at the start of the journey and dependent on outdoor temperature and driving style.



01

## New Passat and Passat Estate GTE Advance.

The new Passat GTE Advance offers even greater levels of styling and technology, with 18 inch 'Monterrey' alloy wheels, LED premium headlights and a range of features including 'Nappa' leather<sup>1</sup> upholstery, panoramic sunroof, Discover Navigation Pro touch-screen navigation/DVD radio system including Car-Net 'Guide and Inform Plus' and Car-Net 'App Connect', Active Info Display, Area view and 'Blue' ambient lighting in the front footwell, front doors, dashboard and centre console combine to create the unique GTE interior.

**01 The Discover Navigation Pro touch-screen navigation/DVD radio system with integrated voice activation, Car-Net 'Guide and Inform Plus'<sup>2</sup> and Car-Net 'App-Connect'<sup>3</sup>** can be operated intuitively via the 8.0 inch TFT colour touch-screen, enabling you to manage music and navigation data. Eight speakers deliver optimum acoustics and the DVD system is compatible with MP3, WMA and AAC files. It also offers a 64 GB SSD hard drive, two SD card readers, photo display from JPEG and PNG files, voice control and USB connection. The Discover Navigation Pro also features 3-years 'Guide and Inform Plus' providing online access to a range of useful information such as traffic, fuel pricing, car park and parking space availability, weather, news feeds and Google Earth. In addition, Car-Net 'App-Connect'<sup>3</sup> combines the functionality of Apple 'CarPlay', Google 'Android Auto' and 'MirrorLink'<sup>™</sup> allowing 'mirroring' of smartphone display on the infotainment touch-screen via USB connection. It cleverly allows display and operation of certified apps including audio and voice control, if supported by the app. Please note, there is usage of only certified apps while driving. You can access many vehicle functions remotely by downloading Volkswagen's Car-Net e-remote mobile services app to your compatible smartphone. You can control charging from a distance, ensure a pleasant interior temperature when you set off or even view information about your driving characteristics and journey. In addition, all functions can be easily controlled via the web portal on [www.volkswagen-carnet.com/uk](http://www.volkswagen-carnet.com/uk)

<sup>1</sup> Some parts of leather interior will contain artificial leather.

<sup>2</sup> Car-Net 'Guide and Inform' services are accessed via a compatible mobile device. Please see [www.volkswagen.co.uk](http://www.volkswagen.co.uk) for more information. The use of 'Guide and Inform Plus' services entails exchanging large volumes of data. As such, we strongly recommend that you sign-up for a flat rate data plan with your mobile network provider. After the initial 3-year Car-Net contract, an annual subscription is chargeable for the continuation of Car-Net 'Guide and Inform Plus' services.

<sup>3</sup> Only operable in conjunction with compatible smartphones including iPhone 5, 6 and 7. Please see [www.volkswagen.co.uk](http://www.volkswagen.co.uk) to check smartphone compatibility.



03

**03 The innovative Active Info Display** ingeniously displays all instrumentation in a fully interactive virtual format, with high quality graphics on a large 12.3 inch screen. As required, important data relating to driving can be pulled up directly within the driver's field of view and configured in an individually selected display. This includes 2D and 3D navigation information, driver assistance systems, driving information and details from the infotainment system, such as phone contacts or music album covers. For example, in 'navigation' mode, the speedometer and rev counter can be relocated to the sides to make more room for the map display.



04

**04 Car-Net 'App-Connect'<sup>3</sup>** combines functionality of Apple 'CarPlay', Google 'Android Auto' and 'MirrorLink'<sup>™</sup> allowing 'mirroring' of a compatible smartphone display on the infotainment touch-screen via USB connection. **Volkswagen apps** such as 'Think Blue. Trainer', 'Shared Audio', 'Drive & Track' or 'My Guide' can help to make your journey more pleasant and interesting, providing useful tips about handling your car, parking opportunities and even where to find the closest café. Please note, there is usage of only certified apps while driving.

**02 LED premium headlights with projection technology** include signature dual 'U-shaped' LED daytime running lights, 12 separate LEDs which perform the indicator function, dynamic curve lighting and headlight washers which assist in keeping them clean.



02



05

**05 Area view** provides a 360-degree view around your Passat GTE Advance helping you manoeuvre easily in any direction. From the display menu, the driver can select the camera views; front, rear, side or bird's-eye view, on either full or split-screen, displayed on the car's infotainment system.

Please refer to your Volkswagen owner's manual for information on system parameters and official guidance on use and operation of all our technology. Image shown is for illustration purposes only.



01

**01 'Aragon'** 6 1/2 J x 16" alloy wheels with 215/60 R16 low rolling resistance tyres and anti-theft wheel bolts. Standard on S models.

**02 'Soho'** 7 J x 17" alloy wheels with 215/55 R17 tyres and anti-theft wheel bolts. Standard on BlueMotion models. Optional on SE Business models.

**03 'London'** 7 J x 17" alloy wheels with 215/55 R17 self-sealing tyres and anti-theft wheel bolts. Standard on SE Business models.

**04 'Oxford Anthracite'** 8 J x 18" alloy wheels with 235/45 R18 self-sealing tyres and anti-theft wheel bolts. Standard on GT and GTE. Optional on SE Business models.

**05 'Kalamata'** 7 J x 18" alloy wheels with 245/45 R18 self-sealing tyres and anti-theft wheel bolts. Standard on Alltrack models.

**06 'Monterrey'** 8 J x 18" alloy wheels with 235/45 R18 self-sealing tyres and anti-theft wheel bolts. Standard on R-Line and GTE Advance. Optional on GTE models.

## Alloy wheels.

Stylish alloy wheels contribute to the charismatic road presence of the Passat and Passat Estate, with a choice of elegant, classic or sporty designs adding a touch of individuality.



02



03



04



05



06



07



08



09



10



11

**07 'Istanbul'** 7 J x 17" alloy wheels with 215/55 R17 tyres and anti-theft wheel bolts. Optional on BlueMotion models.

**08 'Sepang'** 6 1/2 J x 16" alloy wheels with 215/60 R16 tyres and anti-theft wheel bolts. No cost option on SE Business models.

**09 'Nivelles Anthracite'** 7 J x 17" alloy wheels with 215/55 R17 tyres and anti-theft wheel bolts. Optional on SE Business models.

**10 'Marseille Anthracite'** 8 J x 18" alloy wheels with 235/45 R18 tyres and anti-theft wheel bolts. Optional on SE Business, GT, GTE and GTE Advance models.

**11 'Verona'** 8 J x 19" alloy wheels with 235/40 R19 tyres and anti-theft wheel bolts. Optional on GT and R-Line models.

**12 'Albertville'** 8 J x 19" alloy wheels with 245/40 R19 tyres and anti-theft wheel bolts. Optional on Alltrack models.

Please note, the addition of larger optional wheels may result in a higher CO<sub>2</sub> emission figure and change in VED band, and subsequently an increase in the Manufacturer's Recommended 'On the road' Retail price. Please see pages 68-69 for full details.

# Think Blue.

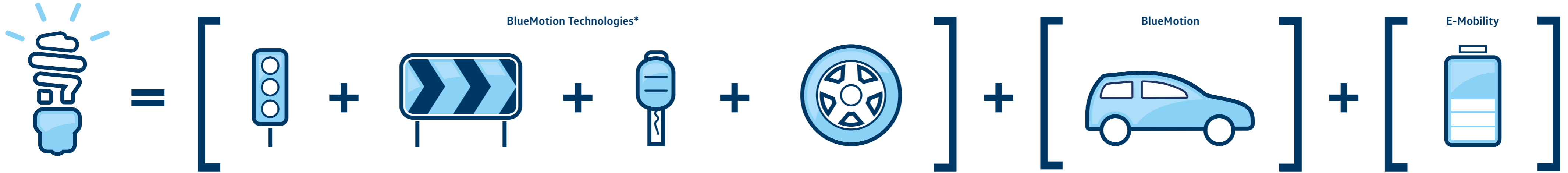

Think Blue.

**Start/Stop technology**  
saves fuel by automatically switching off the engine when the car isn't in motion.

**Brake energy recuperation system**  
makes use of energy that's usually lost when you brake.

**Turbocharged engines**  
deliver more power when you need it and use less fuel when you don't.

**Low rolling resistance tyres**  
reduce the friction between the tyre and the road, meaning it takes less energy – and less fuel – to go further.

**Purpose-built BlueMotion cars**  
include the full range of BlueMotion Technologies as well as an aerodynamically optimised design to reduce wind resistance.

**Electric vehicles**  
comprise both hybrid and fully electric vehicles, offering all the features of their regular counterparts.

\*BlueMotion Technologies are available on all Volkswagens and vary between models.

# Paint.



01

S  BM  SEB  GT  A  RL  GTE



02

S  BM  SEB  GT  A  RL  GTE



03

S  BM  SEB  GT  A  RL  GTE



04

S  BM  SEB  GT  A  RL  GTE



05

S  BM  SEB  GT  A  RL  GTE



06

S  BM  SEB  GT  A



07

S  BM  SEB  GT  A  RL  GTE



08

S  BM  SEB  GT  A  RL  GTE



09

S  BM  SEB  GT  A  RL  GTE



10

S  BM  SEB  GT  A  RL



11

S  BM  SEB  GT  A  RL  GTE

01 Pure White Non-Metallic 0Q

02 Urano Grey Non-Metallic 5K

03 Harvard Blue Metallic 4P

04 Reflex Silver Metallic 8E

05 Tungsten Silver Metallic K5

06 Dark Oak Brown Metallic P0

07 Indium Grey Metallic X3

08 Night Blue Metallic Z2

09 Deep Black Pearl Effect 2T

10 Crimson Red Metallic Signature 5P

11 Oryx White Premium Signature 0R

Please note: Colour range is reproduced for illustration purposes only. Actual on-car colours may vary from those shown, as print processes do not allow exact reproduction of the paint colours.

Standard  Optional at extra cost

S – S BM – BlueMotion SEB – SE Business GT – GT A – Alltrack RL – R-Line GTE – GTE and GTE Advance



# Upholstery.

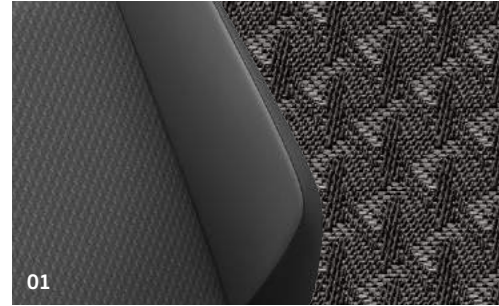

01 S BM



02 SEB



03 SEB



04 GT GTE



05 GT GTE



06 GT



07 A

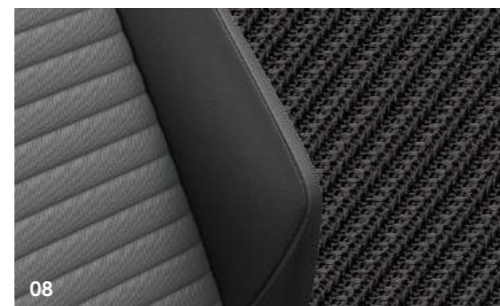

08 RL

- 01 'Hampshire' cloth Titan Black TO
- 02 'Kensington' cloth Titan Black TO
- 03 'Kensington' cloth St Tropez TS
- 04 Alcantara/'Vienna' leather\* Titan Black/Titan Black TO
- 05 Alcantara/'Vienna' leather\* St Tropez/St Tropez TS
- 06 Alcantara/'Vienna' leather\* Moonrock/Black TT
- 07 'Summit' cloth Titan Black TO
- 08 'Race' cloth/'Vienna' leather\* Titan Black/Titan Black IN

■ Standard □ Optional at extra cost

S - S BM - BlueMotion SEB - SE Business GT - GT  
A - Alltrack RL - R-Line GTE - GTE GTE A - GTE Advance



09 SEB A



10 SEB A



11 GTE A GT GTE



12 GT



13 GTE A GT GTE



14 RL



15 RL

- 09 'Vienna' leather\* Titan Black TO
- 10 'Vienna' leather\* St Tropez TS
- 11 'Nappa' leather\* Titan Black TO
- 12 'Nappa' leather\* St Tropez TS
- 13 'Nappa' leather\* Marrakesh LW
- 14 'Nappa' leather\* Flint Grey/Titanium Black OK
- 15 'Nappa' leather\* Titan Black OH

Please note: Swatches reproduced for illustration purposes only. Actual upholstery colours may vary from those shown, as print processes do not allow exact reproduction of the upholstery colours. \* Some parts of leather interior will contain artificial leather.

# Combinations.

Seat upholstery – Standard	Dashboard	Carpet	Rooflining	Pure White Non-Metallic* OQ	Urano Grey Non-Metallic 5K	Harvard Blue Metallic* 4P	Reflex Silver Metallic* 8E	Tungsten Silver Metallic* K5	Dark Oak Brown Metallic* P0	Indium Grey Metallic* X3	Night Blue Metallic* Z2	Deep Black Pearl Effect* 2T	Crimson Red Metallic Signature* 5P	Oryx White Premium Signature* 0R
<b>'Hampshire' cloth</b> Standard on S and BlueMotion Titan Black (TO)	Black	Black	St Tropez	●	●	●	●	●	●	●	●	●	●	●
<b>'Kensington' cloth</b> Standard on SE Business Titan Black (TO)	Black	Black	St Tropez	●	●	●	●	●	●	●	●	●	●	●
St Tropez (TS)	Black/St Tropez	Black	St Tropez	●	●	●	●	●	●	●	●	●	●	●
<b>Alcantara seat centre section and 'Vienna' leather† side bolsters</b> Standard on GT and GTE Titan Black/Titan Black (TO)	Black	Black	St Tropez	●	●	●	●	●	● <sup>1</sup>	●	●	●	● <sup>1</sup>	●
St Tropez/St Tropez (TS)	Black/St Tropez	Black	St Tropez	●	●	●	●	●	● <sup>1</sup>	●	●	●	● <sup>1</sup>	●
Moonrock/Black (TT) <sup>2</sup>	Black	Black	St Tropez	●	●	●	●	●	● <sup>1</sup>	●	●	●	● <sup>1</sup>	●
<b>'Summit' cloth</b> Standard on Alltrack Titan Black (TO)	Black	Black	St Tropez, Black*	●	●	●	●	●	●	●	●	●	●	●
<b>'Race' seat centre section and 'Vienna' leather† side bolsters</b> Standard on R-Line Titan Black/Titan Black (IN)	Black	Black	Black	●	●	●	●	●	-	●	●	●	●	●
<b>'Nappa' leather†</b> Standard on GTE Advance Titan Black (TO)	Black	Black	St Tropez	●	●	●	●	●	-	●	●	●	-	●
St Tropez (TS)	Black/St Tropez	Black	St Tropez	●	●	●	●	●	-	●	●	●	-	●

● Standard. - Not available.

\* Pure White non-metallic, metallic, pearl effect, metallic signature, premium signature paints and black rooflining are optional at extra cost.  
† Some parts of leather interior will contain artificial leather. <sup>1</sup> GT models only. <sup>2</sup> Not available on GTE models.

Image shown features standard 'Kensington' cloth in Titan Black.

# Combinations.

Seat upholstery – Optional	Dashboard	Carpet	Rooflining	Pure White Non-Metallic* 0Q	Urano Grey Non-Metallic 5K	Harvard Blue Metallic* 4P	Reflex Silver Metallic* 8E	Tungsten Silver Metallic* K5	Dark Oak Brown Metallic* P0	Indium Grey Metallic* X3	Night Blue Metallic* Z2	Deep Black Pearl Effect* 2T	Crimson Red Metallic Signature* 5P	Oryx White Premium Signature* 0R
<b>'Vienna' leather*†</b> Optional SE Business														
Titan Black (TO)	Black	Black	St Tropez	○	○	○	○	○	○	○	○	○	○	○
St Tropez (TS)	Black/St Tropez	Black	St Tropez	○	○	○	○	○	○	○	○	○	○	○
<b>'Vienna' leather*†</b> Optional Alltrack														
Titan Black (TO)	Black	Black	St Tropez, Black*	○	○	○	○	○	○	○	○	○	○	○
St Tropez (TS)	Black/St Tropez	Black	St Tropez	○	○	○	○	○	○	○	○	○	○	○
<b>'Nappa' leather*†</b> Optional on GT and GTE														
Titan Black (TO)	Black	Black	St Tropez	○	○	○	○	○	○ <sup>1</sup>	○	○	○	○ <sup>1</sup>	○
St Tropez (TS) <sup>2</sup>	Black/St Tropez	Black	St Tropez	○	○	○	○	○	○ <sup>1</sup>	○	○	○	○ <sup>1</sup>	○
Marrakesh (LW) <sup>3</sup>	Black	Black	St Tropez	○	○	○	○	○	○ <sup>1</sup>	○	○	○	-	○
<b>'Nappa' leather*†</b> Optional on R-Line														
Titan Black (OH)	Black	Black	Black	○	○	-	-	○	-	-	-	○	-	-
Flint Grey/Titanium Black (OK)	Black	Black	Black	○	○	-	-	○	-	-	-	○	-	-
<b>'Nappa' leather*†</b> featuring climate front seats with electric 12-way adjustment and driver's massage and memory function Optional on GT														
Titan Black (OH)	Black	Black	St Tropez	○	○	○	○	○	○	○	○	○	○	○

Image shown features optional 'Nappa' leather in Titan Black.

○ Optional at extra cost. - Not available.

\* Pure White non-metallic, metallic, pearl effect, metallic signature, premium signature paints, leather upholstery, climate front seats and black rooflining are optional at extra cost.

† Some parts of leather interior will contain artificial leather. <sup>1</sup> GT models only. <sup>2</sup> St Tropez 'Nappa' leather does not feature blue highlights and contrast stitching on the gear knob and gear lever gaiter. <sup>3</sup> Not available on GTE models.

# There's a Volkswagen for all of us.

Nippy city run around? Luxurious executive saloon? Open-top cruiser? Whatever it is you're looking for, we probably have it. From the iconic Beetle and Golf GTI to the compact up!, there's a Volkswagen for everyone.

If you're thinking you might like to try a different Volkswagen, there are over 20 models in our range, so there's bound to be at least one that catches your eye.

To see these models and configure your ideal Volkswagen, visit: [www.volkswagen.co.uk](http://www.volkswagen.co.uk)



## Sporty

**Golf:** As exciting to drive as it is to look at. Style, performance and power.

You will also find our sporty gene in the iconic Golf GTD, Golf GTI Clubsport Edition 40 and Golf R.



## Spacious family cars

**Sharan:** The ultimate in convenience with sliding rear doors, and enough space for the whole family. And their luggage. And the dogs.

If it's space you're after, then you might also like to consider the Tiguan, Golf SV, Golf Estate, Touran and Passat Estate.



## Style

**Beetle:** The original icon. And still the most unique way to make a fashion statement.

For more fun with the top down, why not consider the Beetle Cabriolet.



## City run around

**up!:** The ideal city car. Fun, easy to manoeuvre and surprisingly spacious, with that trademark Volkswagen solidity.

If you're looking for something slightly more spacious, then why not consider the up!'s bigger sibling, the Polo. City run around practicality with more versatility and even more space can be found on the iconic Golf.



## Executive

**Volkswagen CC:** Perfectly turned out high-tech, executive luxury. A contemporary, stylish and innovative coupé.

All the luxury you need can also be found in the Jetta, and executive comfort in the Passat and Passat Estate – winner of 'European Car of the Year 2015'.



## 4x4

**Touareg:** The SUV just got smarter. True four by four capability off-road, and smooth, luxurious and powerful when on it, with four wheel drive technology, '4MOTION' as standard.

Go everywhere, do anything in our four wheel drive alternatives: Golf Alltrack, Tiguan and Passat and Passat Estate 4MOTION models.



Model shown is Passat Estate R-Line 2.0 BiTDI 240 PS 4MOTION with optional 19" 'Verona' alloy wheels and metallic paint.

## Built for performance.

The powerful 2.0 litre BiTDI 240 PS 4MOTION with DSG gearbox produces 500Nm of torque, accelerating the Passat Saloon from 0-62mph in 6.1 seconds and the Passat Estate model in a respectable 6.3 seconds. As well as featuring XDS electronic differential lock and Dynamic Chassis Control (DCC), the 2.0 litre BiTDI 240PS 4MOTION features trapezoid tailpipes left and right and LED premium headlights to ensure that it looks just as good as it drives.

# Technical specification – Passat Saloon.

	S, SE Business 1.6 ltr TDI 120 PS BMT	BlueMotion 1.6 ltr TDI SCR 120 PS	GT 1.6 ltr TDI 120 PS BMT	S, SE Business 2.0 ltr TDI 150 PS BMT	GT, R-Line 2.0 ltr TDI 150 PS BMT	GT, R-Line 2.0 ltr TDI SCR 190 PS BMT	GT, R-Line 2.0 ltr BiTDI SCR 240 PS BMT DSG 4MOTION
<b>Engine</b>							
Engine type	4 cylinder diesel	4 cylinder diesel	4 cylinder diesel	4 cylinder diesel	4 cylinder diesel	4 cylinder diesel	4 cylinder diesel
Cubic capacity, ltrs/cc	1.6/1598	1.6/1598	1.6/1598	2.0/1968	2.0/1968	2.0/1968	2.0/1968
Max. output, PS <sup>(01)</sup> /kW	120/88	120/88	120/88	150/110	150/110	190/140	240/176
at rpm	3600-4000	3600-4000	3600-4000	3500-4000	3500-4000	3500-4000	4000
Max. torque, lbs.ft/Nm	185/250	185/250	185/250	251/340	251/340	295/400	369/500
at rpm	1750-3500	1750-3500	1750-3500	1750-3000	1750-3000	1750-3000	1750-2500
Gearbox	6-spd manual 7-spd auto DSG	6-spd manual -	6-spd manual 7-spd auto DSG	6-spd manual 6-spd auto DSG	6-spd manual 6-spd auto DSG	6-spd manual 6-spd auto DSG	- 7-spd auto DSG
<b>Weights, kgs</b>							
Manual gearbox:							
Unladen weight <sup>(02)</sup>	1444	1474	1444	1475	1475	1505	-
Gross vehicle weight	1990	2020	1990	2020	2020	2080	-
Payload <sup>(02)</sup>	621	621	621	620	620	650	-
Axle load limit: Front	1060	1030	1060	1070	1070	1080	-
Rear	980	1040	980	1000	1000	1050	-
Automatic DSG gearbox:							
Unladen weight <sup>(02)</sup>	1459	-	1459	1501	1501	1549	1721
Gross vehicle weight	2000	-	2000	2040	2040	2110	2260
Payload <sup>(02)</sup>	616	-	616	614	614	636	614
Axle load limit: Front	1070	-	1070	1090	1090	1100	1160
Rear	980	-	980	1000	1000	1060	1150
<b>Trailer load limits, kgs <sup>(03)</sup></b>							
Braked 12% incline:							
Manual gearbox	1500	1500	1500	2000	2000	2000	-
Automatic DSG gearbox	1500	-	1500	2000	2000	2000	2200
Unbraked:							
Manual gearbox	720	730	720	730	730	750	-
Automatic DSG gearbox	720	-	720	750	750	750	750
Towbar load limit	90	90	90	90	90	90	90
Max. roof load	100	100	100	100	100	100	100

	S, SE Business 1.6 ltr TDI 120 PS BMT	BlueMotion 1.6 ltr TDI SCR 120 PS BMT	GT 1.6 ltr TDI 120 PS BMT	S, SE Business 2.0 ltr TDI 150 PS BMT	GT, R-Line 2.0 ltr TDI 150 PS BMT	GT, R-Line 2.0 ltr TDI SCR 190 PS BMT	GT, R-Line 2.0 ltr BiTDI SCR 240 PS BMT DSG 4MOTION
<b>Performance</b>							
Top speed, mph (km/h), where the law permits							
Manual gearbox	128 (206)	130 (210)	128 (206)	136 (220)	136 (220)	147 (237)	-
Automatic DSG gearbox	128 (206)	-	128 (206)	135 (218)	135 (218)	146 (235)	149 (240)
Acceleration, secs 0 – 62mph							
Manual gearbox	10.8	10.8	10.8	8.7	8.7	7.9	-
Automatic DSG gearbox	10.8	-	10.8	8.7	8.7	7.7	6.1
ABI insurance group, 1 – 50	15E, 12E	15E	13E	21E, 19E	19E, 19E	22E, 23E	28E, 28E
<b>Environmental information</b>							
Fuel grade, minimum	Diesel <sup>(04)</sup>	Diesel <sup>(04)</sup>	Diesel <sup>(04)</sup>	Diesel <sup>(04)</sup>	Diesel <sup>(04)</sup>	Diesel <sup>(04)</sup>	Diesel <sup>(04)</sup>
Fuel tank capacity, galls/ltrs <sup>(05)</sup>	12.9/59	12.9/59	12.9/59	14.5/66	14.5/66	14.5/66	14.5/66
Official fuel consumption							
manual gearbox,							
mpg/ltr per 100km <sup>(06)</sup>							
Urban	60.1/4.7 <sup>(06)</sup>	65.7/4.3 <sup>(06)</sup>	57.6/4.9 <sup>(06)</sup>	57.6/4.9 <sup>(06)</sup>	56.5/5.0 <sup>(06)</sup>	56.5/5.0 <sup>(06)</sup>	-
Extra-urban	78.5/3.6 <sup>(06)</sup>	85.6/3.3 <sup>(06)</sup>	74.3/3.8 <sup>(06)</sup>	74.3/3.8 <sup>(06)</sup>	72.4/3.9 <sup>(06)</sup>	76.3/3.7 <sup>(06)</sup>	-
Combined	70.6/4.0 <sup>(06)</sup>	76.3/3.7 <sup>(06)</sup>	67.3/4.2 <sup>(06)</sup>	67.3/4.2 <sup>(06)</sup>	65.7/4.3 <sup>(06)</sup>	67.3/4.2 <sup>(06)</sup>	-
Official fuel consumption							
automatic DSG gearbox,							
mpg/ltr per 100km <sup>(06)</sup>							
Urban	61.4/4.6 <sup>(06)</sup>	-	60.1/4.7 <sup>(06)</sup>	53.3/5.3 <sup>(06)</sup>	52.3/5.4 <sup>(06)</sup>	52.3/5.4 <sup>(06)</sup>	42.8/6.6 <sup>(06)</sup>
Extra-urban	74.3/3.8 <sup>(06)</sup>	-	70.6/4.0 <sup>(06)</sup>	68.9/4.1 <sup>(06)</sup>	67.3/4.2 <sup>(06)</sup>	68.9/4.1 <sup>(06)</sup>	57.6/4.9 <sup>(06)</sup>
Combined	68.9/4.1 <sup>(06)</sup>	-	67.3/4.2 <sup>(06)</sup>	62.8/4.5 <sup>(06)</sup>	61.4/4.6 <sup>(06)</sup>	61.4/4.6 <sup>(06)</sup>	51.4/5.5 <sup>(06)</sup>
Official CO <sub>2</sub> emission, g/km							
Manual gearbox <sup>(06)</sup>	105 <sup>(06)</sup>	95 <sup>(06)</sup>	109 <sup>(06)</sup>	109 <sup>(06)</sup>	112 <sup>(06)</sup>	109 <sup>(06)</sup>	-
Automatic DSG gearbox <sup>(06)</sup>	104 <sup>(06)</sup>	-	107 <sup>(06)</sup>	118 <sup>(06)</sup>	121 <sup>(06)</sup>	119 <sup>(06)</sup>	144 <sup>(06)</sup>
Emission class	EURO 6	EURO 6	EURO 6	EURO 6	EURO 6	EURO 6	EURO 6
Noise, dB							
Manual gearbox	70.0	72.0	70.0	72.0	72.0	71.0	-
Automatic DSG gearbox	70.0	-	70.0	67.0	67.0	69.0	69.0

BMT refers to BlueMotion Technology. SCR (Selective Catalytic Reduction) requires AdBlue®, please see page 70 or visit [www.volkswagen.co.uk/technology/adblue](http://www.volkswagen.co.uk/technology/adblue) for more details.

# Technical specification – Passat Estate.

	S, SE Business 1.6 ltr TDI 120 PS BMT	BlueMotion 1.6 ltr TDI SCR 120 PS	GT 1.6 ltr TDI 120 PS BMT	S, SE Business 2.0 ltr TDI 150 PS BMT	GT, R-Line 2.0 ltr TDI 150 PS BMT	GT, R-Line 2.0 ltr TDI SCR 190 PS BMT	GT, R-Line 2.0 ltr BiTDI SCR 240 PS BMT DSG 4MOTION
<b>Engine</b>							
Engine type	4 cylinder diesel	4 cylinder diesel	4 cylinder diesel	4 cylinder diesel	4 cylinder diesel	4 cylinder diesel	4 cylinder diesel
Cubic capacity, ltrs/cc	1.6/1598	1.6/1598	1.6/1598	2.0/1968	2.0/1968	2.0/1968	2.0/1968
Max. output, PS <sup>(01)</sup> /kW	120/88	120/88	120/88	150/110	150/110	190/140	240/176
at rpm	3600-4000	3600-4000	3600-4000	3500-4000	3500-4000	3500-4000	4000
Max. torque, lbs.ft/Nm	185/250	185/250	185/250	251/340	251/340	295/400	369/500
at rpm	1750-3500	1750-3500	1750-3500	1750-3000	1750-3000	1750-3000	1750-2500
Gearbox	6-spd manual 7-spd auto DSG	6-spd manual -	6-spd manual 7-spd auto DSG	6-spd manual 6-spd auto DSG	6-spd manual 6-spd auto DSG	6-spd manual 6-spd auto DSG	- 7-spd auto DSG
<b>Weights, kgs</b>							
Manual gearbox:							
Unladen weight <sup>(02)</sup>	1485	1505	1485	1503	1503	1590	-
Gross vehicle weight	2060	2070	2060	2060	2060	2180	-
Payload <sup>(02)</sup>	650	640	650	632	632	665	-
Axle load limit: Front	1040	1020	1040	1050	1050	1080	-
Rear	1070	1100	1070	1070	1070	1150	-
Automatic DSG gearbox:							
Unladen weight <sup>(02)</sup>	1500	-	1500	1541	1541	1581	1735
Gross vehicle weight	2060	-	2060	2130	2130	2170	2310
Payload <sup>(02)</sup>	635	-	635	664	664	664	650
Axle load limit: Front	1050	-	1050	1100	1100	1100	1140
Rear	1060	-	1060	1080	1080	1120	1220
<b>Trailer load limits, kgs <sup>(03)</sup></b>							
Braked 12% incline:							
Manual gearbox	1500	1500	1500	2000	2000	2000	-
Automatic DSG gearbox	1500	-	1500	2000	2000	2000	2200
Unbraked:							
Manual gearbox	740	750	740	750	750	750	-
Automatic DSG gearbox	750	-	750	750	750	750	750
Towbar load limit	90	90	90	90	90	90	90
Max. roof load	100	100	100	100	100	100	100

	S, SE Business 1.6 ltr TDI 120 PS BMT	BlueMotion 1.6 ltr TDI SCR 120 PS	GT 1.6 ltr TDI 120 PS BMT	S, SE Business 2.0 ltr TDI 150 PS BMT	GT, R-Line 2.0 ltr TDI 150 PS BMT	GT, R-Line 2.0 ltr TDI SCR 190 PS BMT	GT, R-Line 2.0 ltr BiTDI SCR 240 PS BMT DSG 4MOTION
<b>Performance</b>							
Top speed, mph (km/h), where the law permits							
Manual gearbox	127 (204)	129 (208)	127 (204)	135 (218)	135 (218)	146 (235)	-
Automatic DSG gearbox	127 (204)	-	127 (204)	134 (216)	134 (216)	144 (233)	147 (238)
Acceleration, secs 0 – 62mph							
Manual gearbox	11.0	11.0	11.0	8.9	8.9	8.1	-
Automatic DSG gearbox	11.0	-	11.0	8.9	8.9	7.9	6.3
ABI insurance group, 1 – 50	15E, 12E	15E	13E	21E, 19E	19E, 19E	22E, 23E	28E, 28E
<b>Environmental information</b>							
Fuel grade, minimum	Diesel <sup>(04)</sup>	Diesel <sup>(04)</sup>	Diesel <sup>(04)</sup>	Diesel <sup>(04)</sup>	Diesel <sup>(04)</sup>	Diesel <sup>(04)</sup>	Diesel <sup>(04)</sup>
Fuel tank capacity, galls/ltrs <sup>(05)</sup>	12.9/59	12.9/59	12.9/59	14.5/66	14.5/66	14.5/66	14.5/66
Official fuel consumption							
manual gearbox,							
mpg/ltr per 100km <sup>(06)</sup>							
Urban	58.9/4.8 <sup>(06)</sup>	64.2/4.4 <sup>(06)</sup>	57.6/4.9 <sup>(06)</sup>	57.6/4.9 <sup>(06)</sup>	56.5/5.0 <sup>(06)</sup>	55.4/5.1 <sup>(06)</sup>	-
Extra-urban	76.3/3.7 <sup>(06)</sup>	83.1/3.4 <sup>(06)</sup>	74.3/3.8 <sup>(06)</sup>	72.4/3.9 <sup>(06)</sup>	70.6/4.0 <sup>(06)</sup>	72.4/3.9 <sup>(06)</sup>	-
Combined	68.9/4.1 <sup>(06)</sup>	74.3/3.8 <sup>(06)</sup>	67.3/4.2 <sup>(06)</sup>	67.3/4.2 <sup>(06)</sup>	65.7/4.3 <sup>(06)</sup>	65.7/4.3 <sup>(06)</sup>	-
Official fuel consumption							
automatic DSG gearbox,							
mpg/ltr per 100km <sup>(06)</sup>							
Urban	62.8/4.5 <sup>(06)</sup>	-	61.4/4.6 <sup>(06)</sup>	52.3/5.4 <sup>(06)</sup>	50.4/5.6 <sup>(06)</sup>	52.3/5.4 <sup>(06)</sup>	42.2/6.7 <sup>(06)</sup>
Extra-urban	76.3/3.7 <sup>(06)</sup>	-	72.4/3.9 <sup>(06)</sup>	67.3/4.2 <sup>(06)</sup>	64.2/4.4 <sup>(06)</sup>	68.9/4.1 <sup>(06)</sup>	56.5/5.0 <sup>(06)</sup>
Combined	70.6/4.0 <sup>(06)</sup>	-	68.9/4.1 <sup>(06)</sup>	61.4/4.6 <sup>(06)</sup>	58.9/4.8 <sup>(06)</sup>	61.4/4.6 <sup>(06)</sup>	50.4/5.6 <sup>(06)</sup>
Official CO <sub>2</sub> emission, g/km							
Manual gearbox <sup>(06)</sup>	107 <sup>(06)</sup>	96 <sup>(06)</sup>	110 <sup>(06)</sup>	110 <sup>(06)</sup>	113 <sup>(06)</sup>	111 <sup>(06)</sup>	-
Automatic DSG gearbox <sup>(06)</sup>	104 <sup>(06)</sup>	-	107 <sup>(06)</sup>	121 <sup>(06)</sup>	124 <sup>(06)</sup>	120 <sup>(06)</sup>	146 <sup>(06)</sup>
Emission class	EURO 6	EURO 6	EURO 6	EURO 6	EURO 6	EURO 6	EURO 6
Noise, dB							
Manual gearbox	70.0	72.0	70.0	72.0	72.0	71.0	-
Automatic DSG gearbox	70.0	-	70.0	67.0	67.0	69.0	69.0

BMT refers to BlueMotion Technology. SCR (Selective Catalytic Reduction) requires AdBlue®, please see page 70 or visit [www.volkswagen.co.uk/technology/adblue](http://www.volkswagen.co.uk/technology/adblue) for more details.

# Technical specification – Passat Alltrack.

	<b>Alltrack 2.0 ltr TDI SCR 150 PS BMT 4MOTION</b>	<b>Alltrack 2.0 ltr TDI SCR 190 PS BMT DSG 4MOTION</b>
<b>Engine</b>		
Engine type	4 cylinder diesel	4 cylinder diesel
Cubic capacity, ltrs/cc	2.0/1968	2.0/1968
Max. output, PS <sup>(01)</sup> /kW	150/110	190/140
at rpm	3500-4000	3600-4000
Max. torque, lbs.ft/Nm	251/340	295/400
at rpm	1750-3000	1900-3300
Gearbox	6-spd manual	–
	–	6-spd auto DSG

## Weights, kgs

Manual gearbox:		
Unladen weight <sup>(02)</sup>	1670	–
Gross vehicle weight	2260	–
Payload <sup>(02)</sup>	665	–
Axle load limit: Front	1100	–
Rear	1210	–
Automatic DSG gearbox:		
Unladen weight <sup>(02)</sup>	–	1705
Gross vehicle weight	–	2290
Payload <sup>(02)</sup>	–	660
Axle load limit: Front	–	1120
Rear	–	1220

## Trailer load limits, kgs <sup>(03)</sup>

Braked 12% incline:		
Manual gearbox	2200	–
Automatic DSG gearbox	–	2200
Unbraked:		
Manual gearbox	750	–
Automatic DSG gearbox	–	750
Towbar load limit	90	90
Max. roof load	100	100

	<b>Alltrack 2.0 ltr TDI SCR 150 PS BMT 4MOTION</b>	<b>Alltrack 2.0 ltr TDI SCR 190 PS BMT DSG 4MOTION</b>
<b>Performance</b>		
Top speed, mph (km/h), where the law permits		
Manual gearbox	127 (205)	–
Automatic DSG gearbox	–	136 (220)
Acceleration, secs 0 – 62mph		
Manual gearbox	9.2	–
Automatic DSG gearbox	–	8.0
ABI insurance group, 1 - 50	TBA	TBA

## Environmental information

Fuel grade, minimum	Diesel <sup>(04)</sup>	Diesel <sup>(04)</sup>
Fuel tank capacity, galls/ltrs <sup>(05)</sup>	12.9/59	14.5/66
Official fuel consumption		
manual gearbox,		
mpg/ltr per 100km <sup>(06)</sup>		
Urban	47.9/5.9 <sup>(06)</sup>	–
Extra-urban	65.7/4.3 <sup>(06)</sup>	–
Combined	57.6/4.9 <sup>(06)</sup>	–
Official fuel consumption		
automatic DSG gearbox,		
mpg/ltr per 100km <sup>(06)</sup>		
Urban	–	46.3/6.1 <sup>(06)</sup>
Extra-urban	–	60.1/4.7 <sup>(06)</sup>
Combined	–	54.3/5.2 <sup>(06)</sup>

Official CO <sub>2</sub> emission, g/km		
Manual gearbox <sup>(06)</sup>	130 <sup>(06)</sup>	–
Automatic DSG gearbox <sup>(06)</sup>	–	137 <sup>(06)</sup>
Emission class	EURO 6	EURO 6
Noise, dB		
Manual gearbox	73.0	–
Automatic DSG gearbox	–	69.0

BMT refers to BlueMotion Technology.

SCR (Selective Catalytic Reduction) requires AdBlue®, please see page 70 or visit [www.volkswagen.co.uk/technology/adblue](http://www.volkswagen.co.uk/technology/adblue) for more details.

# Technology.

## Technical specification notes

- The maximum power output figures are quoted in PS (or Pferdestärke, which is the metric equivalent of horsepower). To convert from metric to imperial horsepower, divide the PS figure by 1.0139.
- Figures are calculated in accordance with manufacturer’s criteria. The individual unladen weight depends on the specification of the vehicle, this then reduces the possible payload accordingly. The unladen weight and payload both include the fuel tank 90% full, driver (68kg) and luggage (7kg) in line with EU directive 95/48.
- With increasing altitude the engine performance diminishes. From 1,000m above sea level and for every 1,000m thereafter 10% of the vehicle/trailer weight (trailer weight + gross vehicle weight) must be deducted.
- The use of 100% RME and FAME (bio diesel) is not possible. Forecourt diesel with up to 7% bio diesel content, adhering to standard BS EN 590, can be used in diesel engines. The use of ethanol in forecourt petrol meeting BS EN 228 is allowable.
- The size of the fuel tank is approximate and therefore it may be possible to add a greater amount of fuel than the size of the tank specified, due to the space in the filler neck.
- Fuel consumption and CO<sub>2</sub> figures are obtained under standardised EU test conditions (Directive 93/116/EEC). This allows a direct comparison between different manufacturer models but may not represent the actual fuel consumption achieved in ‘real world’ driving conditions. More information is available on the Volkswagen website at [www.volkswagen.co.uk](http://www.volkswagen.co.uk) and at [www.dft.gov.uk/vca](http://www.dft.gov.uk/vca). The weight of a vehicle will influence the level of CO<sub>2</sub> emissions it produces; as a result, vehicles with higher levels of specification and factory-fitted options may emit higher levels of CO<sub>2</sub>. Choosing larger alloy wheels than those fitted as standard may result in increased fuel consumption as well as higher CO<sub>2</sub> emissions and subsequently an increased Vehicle Excise Duty (VED) band. BIK rates paid by company car drivers may also increase. In some instances, the recommended ‘On the road’ retail price paid for a vehicle may increase as a result of the increased VED rate. CO<sub>2</sub> is the main greenhouse gas responsible for global warming. The specifications contained in this brochure are for information purposes only and are subject to change.

## Transmission

- Electronic differential lock, combined with a hydraulically operated single-plate dry clutch with asbestos-free lining via a six manual or six and seven speed automatic DSG gearbox
- Front wheel drive through asbestos-free single-plate dry clutch. Hydraulic clutch-mechanism. Six speed manual, six or seven speed automatic DSG gearbox with double joint half axles (wet clutch on six speed DSG models)
- Four wheel drive, 4MOTION: Six speed manual 2.0 litre TDI SCR 150 PS. Six speed automatic DSG 2.0 litre TDI SCR 190 PS. Seven speed automatic DSG 2.0 litre BiTDI SCR 240 PS

## Brakes

- Electronically controlled Anti-lock Braking System (ABS) with Electronic Brake-pressure Distribution (EBD)
- Diagonal twin-circuit brake system with ventilated front disc brakes and rear disc brakes
- Asbestos-free brake pad
- HBA (Hydraulic Brake Assist)

## AdBlue®

SCR (Selective Catalytic Reduction) requires AdBlue®, please see page 70 or visit [www.volkswagen.co.uk/technology/adblue](http://www.volkswagen.co.uk/technology/adblue) for more details.

## Running gear

- ESC (Electronic Stability Control) including EDL (Electronic Differential Lock), ASR (Traction Control), EDTC (Engine Drag Torque Control) and Countersteer Support with trailer stabilisation function
- Front suspension through coil springs with telescopic shock absorbers, all elements integrated in chassis legs
- Rear suspension with gas pressure shock absorbers and separate springs
- Multilink rear axle
- Wheel control: front through chassis legs and (lower) triangular wishbones (directionally stabilising steering roll radius)
- Wheel control: rear through four-link suspension with independent wheel suspension
- Front and rear anti-roll bar
- XDS electronic differential lock (2.0 litre BiTDI SCR 240 PS 4MOTION only)

## Steering

- Electro-mechanical steering rack
- Collapsible, height and lengthways adjustable safety steering column

## Engines

- Front transverse-installed engine
- 1.6 litre/120 PS <sup>(01)</sup> (88 kW) common rail diesel engine: EU6 emissions standard, four cylinder in-line common rail diesel engine, with four valves per cylinder. Fitted with a turbocharger and a DPF (diesel particulate filter). Available with a six speed manual or a seven speed automatic DSG transmission
- 1.6 litre/120 PS <sup>(01)</sup> (88 kW) common rail diesel engine: EU6 emissions standard, four cylinder in-line common rail diesel engine, with four valves per cylinder. Fitted with a turbocharger and a DPF (diesel particulate filter) with SCR (Selective Catalytic Reduction). Available with a six speed manual transmission
- 2.0 litre/150 PS <sup>(01)</sup> (110 kW) common rail diesel engine: EU6 emissions standard, four cylinder in-line common rail diesel engine, with four valves per cylinder. Fitted with a turbocharger and a DPF (diesel particulate filter). Available with a six speed manual or a six speed automatic DSG transmission
- 2.0 litre/150 PS <sup>(01)</sup> (110 kW) common rail diesel engine: EU6 emissions standard, four cylinder in-line common rail diesel engine, with four valves per cylinder. Fitted with a turbocharger and a DPF (diesel particulate filter) with SCR (Selective Catalytic Reduction). Available with a six speed manual transmission
- 2.0 litre/190 PS <sup>(01)</sup> (140 kW) common rail diesel engine: EU6 emissions standard, four cylinder in-line common rail diesel engine, with four valves per cylinder. Fitted with a turbocharger and a DPF (diesel particulate filter) with SCR (Selective Catalytic Reduction). Available with a six speed manual or a six speed automatic DSG transmission
- 2.0 litre/240 PS <sup>(01)</sup> (176 kW) common rail diesel engine: EU6 emissions standard, four cylinder in-line common rail diesel engine, with four valves per cylinder. Fitted with a turbocharger and a DPF (diesel particulate filter) with SCR (Selective Catalytic Reduction). BiTurbo second turbocharger or supercharger. Available with a seven speed automatic DSG transmission



# Technical specification – New Passat GTE and GTE Advance.

<b>Engine</b>	
Engine type	4 cylinder petrol. TSI Plug-In-Hybrid
Cubic capacity, ltrs/cc	1.4/1395
Injection/Charge	Direct injection/Turbocharger
Max output, PS <sup>(01)</sup> /kW	156/115
at rpm	5000-6000
Max. torque, lbs.ft/Nm	184/250
at rpm	1500-3500
Gearbox	6-spd auto DSG

#### Electric motor/charging system

Electrical power, PS <sup>(01)</sup> /kW	115/85
at rpm	2500
Combined max output, PS <sup>(01)</sup> /kW	218/160
Combined max torque, lbs.ft/Nm	295/400
Battery type	Lithium-ion
Battery energy capacity, kWh	9.9
Charging time: AC 2.3 kW, 100% State of Charge, hour:min	4:15
AC 3.6 kW, 100% State of Charge, hour:min	2:30

#### Performance (at kerb weight + 200kg)

Top speed, mph (km/h), where the law permits	140 (225)
Saloon – Acceleration, secs 0 – 62mph	7.4
Estate – Acceleration, secs 0 – 62mph	7.6
ABI insurance group, 1 - 50	26E

#### Fuel consumption (99/100EC)

Fuel grade minimum	Premium, 95 RON
Fuel tank capacity, galls/ltrs <sup>(02)</sup>	11/50
Combined, mpg/ltr 100km <sup>(03)</sup>	156.9/1.8 <sup>(03)</sup>
Combined official CO <sub>2</sub> emission, g/km <sup>(03)</sup>	40 <sup>(03)</sup>
Emission class	EURO 6

<b>Saloon</b>	
<b>Electrical power consumption kWh/62 miles</b>	
Combined, kWh/62 miles <sup>(04)</sup>	13.1
Official CO <sub>2</sub> emission, g/km (in 'e-mode', whilst in motion)	0
Efficiency class <sup>(05)</sup>	A+

#### Estate

<b>Electrical power consumption kWh/62 miles</b>	
Combined, kWh/62 miles <sup>(04)</sup>	13.2
Official CO <sub>2</sub> emission, g/km (in 'e-mode', whilst in motion)	0
Efficiency class <sup>(05)</sup>	A+

#### Driving range

Electric driving range (NEDC), miles/km <sup>(06)</sup>	31/50
Total range (NEDC), miles/km <sup>(06)</sup>	664

#### Saloon

<b>Weights, kgs <sup>(07)</sup></b>	
Unladen weight <sup>(08)</sup>	1722
Gross vehicle weight	2200
Payload <sup>(08)</sup>	553
Axle load limit: Front	1110
Rear	1140
Braked 12% incline	1600
Unbraked	750

#### Estate

<b>Weights, kgs <sup>(07)</sup></b>	
Unladen weight <sup>(08)</sup>	1735
Gross vehicle weight	2250
Payload <sup>(08)</sup>	590
Axle load limit: Front	1100
Rear	1200
Braked 12% incline	1600
Unbraked	750

#### Noise, dB

Automatic DSG gearbox	73
-----------------------	----

# Technology.

#### Technical specification notes

- The maximum power output figures are quoted in PS (or Pferdestärke, which is the metric equivalent of horsepower). To convert from metric to imperial horsepower, divide the PS figure by 1.0139.
- The size of the fuel tank is approximate and therefore it may be possible to add a greater amount of fuel than the size of the tank specified, due to the space in the filler neck.
- Fuel consumption and CO<sub>2</sub> figures are obtained under standardised EU test conditions (Directive 93/116/EEC). This allows a direct comparison between different manufacturer models but may not represent the actual fuel consumption achieved in 'real world' driving conditions. More information is available on the Volkswagen website at www.volkswagen.co.uk and at www.dft.gov.uk/vca. The weight of a vehicle will influence the level of CO<sub>2</sub> emissions it produces; as a result, vehicles with higher levels of specification and factory-fitted options may emit higher levels of CO<sub>2</sub>. Choosing larger alloy wheels than those fitted as standard may result in increased fuel consumption as well as higher CO<sub>2</sub> emissions and subsequently an increased Vehicle Excise Duty (VED) band. BIK rates paid by company car drivers may also increase. In some instances, the recommended 'On the road' retail price paid for a vehicle may increase as a result of the increased VED rate. The specifications contained in this brochure are for information purposes only and are subject to change.
- The 'combined/weighted' fuel consumption/CO<sub>2</sub> figures are calculated from two test results: one when the battery is fully charged and another when the battery is discharged. The two results are a weighted average, taking into account mileage range on battery power only, providing a figure in a variety of charge conditions. Battery charged using mains-sourced electricity via plug-in. Extended range achieved by 1.4 litre TSI petrol engine generating electricity. Fuel consumption and CO<sub>2</sub> emissions figures are obtained under standardised test conditions (Directive 93/116/EEC) using a representative model. This allows direct comparison between different models from different manufacturers, but may not represent the actual fuel consumption achieved in 'real world' driving conditions. Emissions are while driving. Extra equipment and accessories (add-on parts, tyres etc.) can change relevant vehicle parameters, such as weight, rolling resistance and aerodynamics, and with weather and traffic conditions, can affect consumption and performance values.
- Efficiency classes assess vehicles according to CO<sub>2</sub> emissions, taking into account the vehicle's unladen weight. Vehicles conforming to that are graded D. Vehicles that are better than today's average are graded A+, A, B or C. Vehicles that are worse than the average are graded E, F or G.
- The specified NEDC range can vary because of driving style, speed, use of additional electrical consuming equipment, outside temperature, number of people in car/maximum load, driving style selection (e-mode, hybrid, battery charge or GTE) and terrain.
- With increasing altitude the engine performance diminishes. From 1,000m above sea level and for every 1,000m thereafter 10% of the vehicle/trailer weight (trailer weight + gross vehicle weight) must be deducted.
- Figures are calculated in accordance with manufacturer's criteria. The individual unladen weight depends on the specification of the vehicle, this then reduces the possible payload accordingly. The unladen weight and payload both include the fuel tank 90% full, driver (68kg) and luggage (7kg) in line with EU directive 95/48.

#### Transmission

- Electronic differential lock, combined with a hydraulically operated single-plate dry clutch with asbestos-free lining via a six speed automatic DSG gearbox
- Front wheel drive through asbestos-free single-plate dry clutch. Hydraulic clutch-mechanism. Six speed automatic DSG gearbox with double joint half axles (wet clutch on six speed DSG models)

#### Running gear

- ESC (Electronic Stability Control) including EDL (Electronic Differential Lock), ASR (Traction Control), EDTC (Engine Drag Torque Control) and Countersteer Support with trailer stabilisation function
- Front suspension through coil springs with telescopic shock absorbers, all elements integrated in chassis legs
- Rear suspension with gas pressure shock absorbers and separate springs
- Multilink rear axle
- Wheel control: front through chassis legs and (lower) triangular wishbones (directionally stabilising steering roll radius)
- Wheel control: rear through four-link suspension with independent wheel suspension
- Front and rear anti-roll bar

#### Steering

- Electro-mechanical steering rack
- Collapsible, height and lengthways adjustable safety steering column

#### Brakes

- Electronically controlled Anti-lock Braking System (ABS) with Electronic Brake-pressure Distribution (EBD)
- Diagonal twin-circuit brake system with ventilated front disc brakes and rear disc brakes
- Asbestos-free brake pad
- HBA (Hydraulic Brake Assist)

#### Engine

- Front transverse-installed engine
- 1.4 litre/156 PS <sup>(01)</sup> (115 kW) petrol engine: EU6 emissions standard, four cylinder in-line direct injection turbocharged engine, with four valves per cylinder. Fitted with a turbocharger. Available with a six speed automatic DSG transmission

# Dimensions.

Exterior dimensions	Passat Saloon
Length, mm	4767
Width - including door mirrors, mm	2083
Width - opened front/rear doors, mm	3798/3685
Height - mm	1456
Height - opened bonnet/floor, mm	1782
Height - opened tailgate/floor, mm	1747
Wheelbase, mm	2791
Turning circle, m	11.7

Interior dimensions	Passat Saloon
Effective headroom - front, mm (with sunroof)	1034 (993)
Effective headroom - rear, mm (with sunroof)	964 (964)
Elbow width, front, mm	1506
Elbow width, rear, mm	1506
Legroom front, mm	1045
Legroom rear, mm	973

Maximum luggage capacity, litres VDA measuring method using 200 x 100 x 50mm blocks	Passat Saloon
With rear seats upright	586
With rear seats folded	1152

Figures shown are for standard specification models. The addition of certain factory-fitted options and/or accessories may affect some of the dimensions shown.

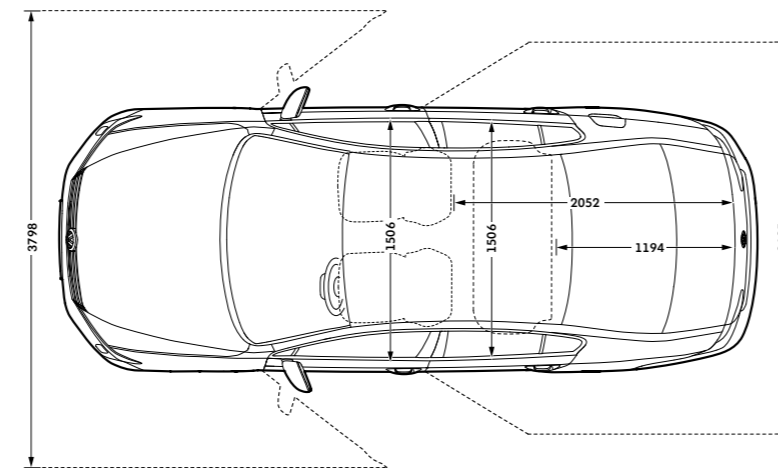
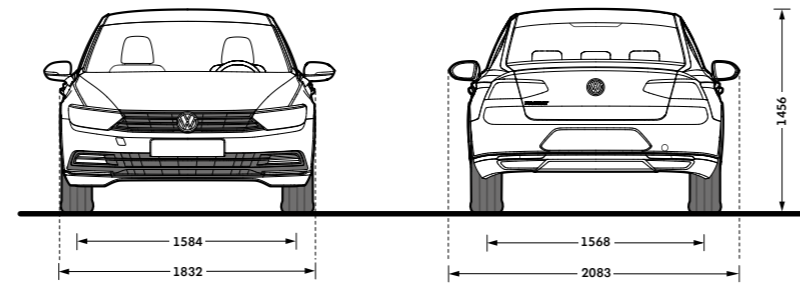
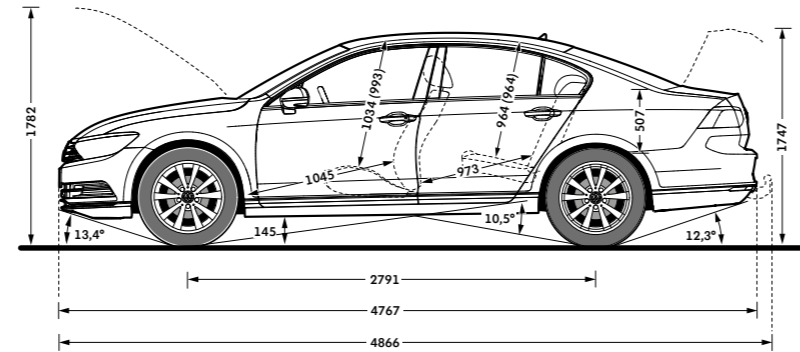

On illustrations, where arrows and figures are shown inside of the vehicle, the measurements are for interior dimensions. Where arrows and figures are shown outside of the vehicle, the measurements are for exterior dimensions.

Exterior dimensions	Passat Estate	Passat Alltrack
Length, mm	4767	4777
Width - including door mirrors, mm	2083	2083
Width - opened front/rear doors, mm	3798/3594	TBA
Height - mm	1477	1506
Height - opened bonnet/floor, mm	1782	TBA
Height - opened tailgate/floor, mm	2047	2076
Wheelbase, mm	2791	2789
Turning circle, m	11.7	11.7

Interior dimensions	Passat Estate	Passat Alltrack
Effective headroom - front, mm (with sunroof)	985 (949)	1031 (990)
Effective headroom - rear, mm (with sunroof)	1007 (972)	1007 (972)
Elbow width, front, mm	1506	1506
Elbow width, rear, mm	1506	1506
Legroom front, mm	1045	TBA
Legroom rear, mm	973	TBA

Maximum luggage capacity, litres VDA measuring method using 200 x 100 x 50mm blocks	Passat Estate	Passat Alltrack
With rear seats upright	650	639
With rear seats folded	1780	1769

Figures shown are for standard specification models. The addition of certain factory-fitted options and/or accessories may affect some of the dimensions shown.

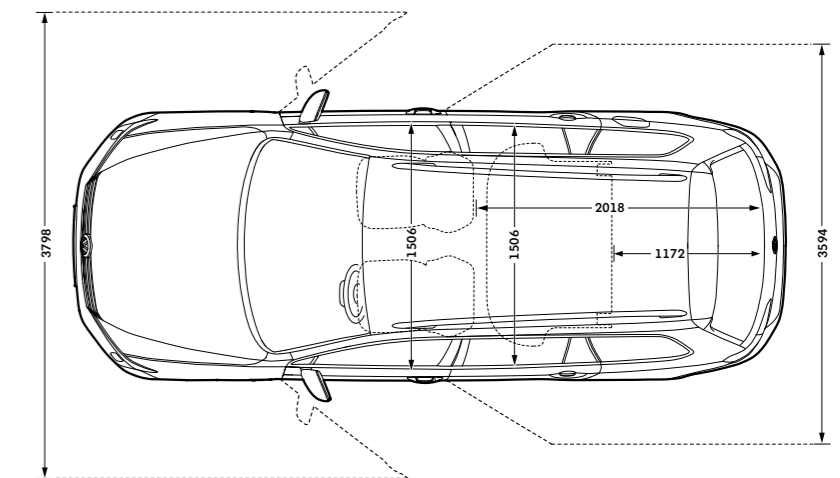
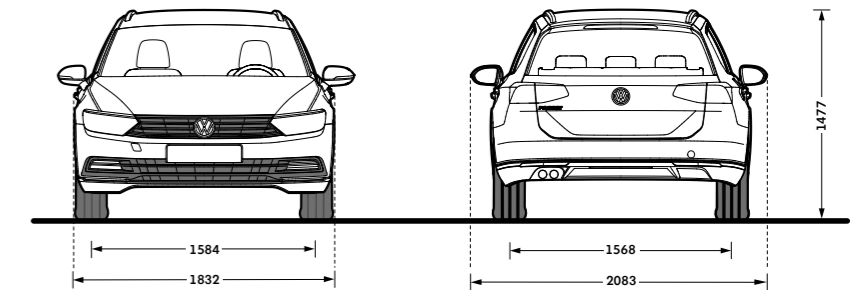
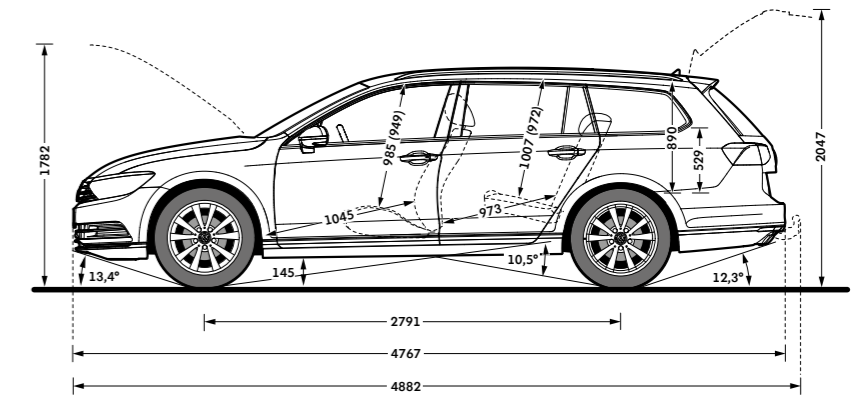

On illustrations, where arrows and figures are shown inside of the vehicle, the measurements are for interior dimensions. Where arrows and figures are shown outside of the vehicle, the measurements are for exterior dimensions.

# CO<sub>2</sub> emissions and VED bands with optional wheels.

## Effect of wheel size on CO<sub>2</sub> emissions and VED Bands

Choosing larger alloy wheels than standard as an option, may result in increased fuel consumption as well as higher CO<sub>2</sub> emissions and subsequently increased Vehicle Excise Duty (VED) band. The BIK rates paid by company car drivers may also increase. This is due to the fact that larger wheels have both more aerodynamic drag and more mechanical drag, resulting in increased rolling resistance and increased wind resistance. As a result, the VED band that the vehicle falls into may increase from its original VED band when fitted with standard size wheels. In some instances, the recommended 'On the road' retail price paid for the vehicle may increase as a result of the increased VED rate. The chart below shows CO<sub>2</sub> emissions and the related VED bands for vehicles with both standard-fit wheels and larger optional alloy wheels.

4-door saloon range		Output, PS	Standard wheel size	CO <sub>2</sub> emission, g/km*, standard wheels	VED Band, standard wheels	Optional alloy wheel and size	CO <sub>2</sub> emission, g/km*, optional alloy wheels	VED Band, optional wheels
<b>S</b>	1.6 ltr TDI <a href="#">BMT</a>	6 speed manual	120	16"	105*	N/A	N/A	N/A
	1.6 ltr TDI <a href="#">BMT</a>	7 speed auto DSG	120	16"	104*	N/A	N/A	N/A
	2.0 ltr TDI <a href="#">BMT</a>	6 speed manual	150	16"	109*	N/A	N/A	N/A
	2.0 ltr TDI <a href="#">BMT</a>	6 speed auto DSG	150	16"	118*	N/A	N/A	N/A
<b>BlueMotion</b>	1.6 ltr TDI SCR <a href="#">BM</a>	6 speed manual	120	17"	95*	17" Istanbul	95*	A
<b>SE Business</b>	1.6 ltr TDI <a href="#">BMT</a>	6 speed manual	120	17"	105*	16" Sepang, 17" Nivelles Anthracite, 17" Soho	105*	B
		6 speed manual	120	17"	105*	18" Oxford Anthracite, 18" Marseille Anthracite	109*	B
	1.6 ltr TDI <a href="#">BMT</a>	7 speed auto DSG	120	17"	104*	16" Sepang, 17" Nivelles Anthracite, 17" Soho	104*	B
		7 speed auto DSG	120	17"	104*	18" Oxford Anthracite, 18" Marseille Anthracite	107*	B
	2.0 ltr TDI <a href="#">BMT</a>	6 speed manual	150	17"	109*	16" Sepang, 17" Nivelles Anthracite, 17" Soho	109*	B
		6 speed manual	150	17"	109*	18" Oxford Anthracite, 18" Marseille Anthracite	112*	C
	2.0 ltr TDI <a href="#">BMT</a>	6 speed auto DSG	150	17"	118*	16" Sepang, 17" Nivelles Anthracite, 17" Soho	118*	C
		6 speed auto DSG	150	17"	118*	18" Oxford Anthracite, 18" Marseille Anthracite	121*	D
<b>GT</b>	1.6 ltr TDI <a href="#">BMT</a>	6 speed manual	120	18"	109*	18" Marseille Anthracite, 19" Verona	109*	B
	1.6 ltr TDI <a href="#">BMT</a>	7 speed auto DSG	120	18"	107*	18" Marseille Anthracite, 19" Verona	107*	B
	2.0 ltr TDI <a href="#">BMT</a>	6 speed manual	150	18"	112*	18" Marseille Anthracite, 19" Verona	112*	C
	2.0 ltr TDI <a href="#">BMT</a>	6 speed auto DSG	150	18"	121*	18" Marseille Anthracite, 19" Verona	121*	D
	2.0 ltr TDI SCR <a href="#">BMT</a>	6 speed manual	190	18"	109*	18" Marseille Anthracite, 19" Verona	109*	B
	2.0 ltr TDI SCR <a href="#">BMT</a>	6 speed auto DSG	190	18"	119*	18" Marseille Anthracite, 19" Verona	119*	C
	2.0 ltr BiTDI SCR <a href="#">BMT</a> 4MOTION	7 speed auto DSG	240	18"	144*	18" Marseille Anthracite, 19" Verona	144*	F
<b>R-Line</b>	2.0 ltr TDI <a href="#">BMT</a>	6 speed manual	150	18"	112*	19" Verona	112*	C
	2.0 ltr TDI <a href="#">BMT</a>	6 speed auto DSG	150	18"	121*	19" Verona	121*	D
	2.0 ltr TDI SCR <a href="#">BMT</a>	6 speed manual	190	18"	109*	19" Verona	109*	B
	2.0 ltr TDI SCR <a href="#">BMT</a>	6 speed auto DSG	190	18"	119*	19" Verona	119*	C
	2.0 ltr BiTDI SCR <a href="#">BMT</a> 4MOTION	7 speed auto DSG	240	18"	144*	19" Verona	144*	F
<b>GTE</b>	1.4 ltr TSI <a href="#">BMT</a> /Electric Motor	6 speed auto DSG	218	18"	40*	18" Marseille Anthracite, 18" Monterrey	40*	A
<b>GTE Advance</b>	1.4 ltr TSI <a href="#">BMT</a> /Electric Motor	6 speed auto DSG	218	18"	40*	18" Marseille Anthracite	40*	A

5-door estate range		Output, PS	Standard wheel size	CO <sub>2</sub> emission, g/km*, standard wheels	VED Band, standard wheels	Optional alloy wheel and size	CO <sub>2</sub> emission, g/km*, optional alloy wheels	VED Band, optional wheels
<b>S</b>	1.6 ltr TDI <a href="#">BMT</a>	6 speed manual	120	16"	107*	N/A	N/A	N/A
	1.6 ltr TDI <a href="#">BMT</a>	7 speed auto DSG	120	16"	104*	N/A	N/A	N/A
	2.0 ltr TDI <a href="#">BMT</a>	6 speed manual	150	16"	110*	N/A	N/A	N/A
	2.0 ltr TDI <a href="#">BMT</a>	6 speed auto DSG	150	16"	121*	N/A	N/A	N/A
<b>BlueMotion</b>	1.6 ltr TDI SCR <a href="#">BM</a>	6 speed manual	120	17"	96*	17" Istanbul	96*	A
<b>SE Business</b>	1.6 ltr TDI <a href="#">BMT</a>	6 speed manual	120	17"	107*	16" Sepang, 17" Nivelles Anthracite, 17" Soho	107*	B
		6 speed manual	120	17"	107*	18" Oxford Anthracite, 18" Marseille Anthracite	110*	B
	1.6 ltr TDI <a href="#">BMT</a>	7 speed auto DSG	120	17"	104*	16" Sepang, 17" Nivelles Anthracite, 17" Soho	104*	B
		7 speed auto DSG	120	17"	104*	18" Oxford Anthracite, 18" Marseille Anthracite	107*	B
	2.0 ltr TDI <a href="#">BMT</a>	6 speed manual	150	17"	110*	16" Sepang, 17" Nivelles Anthracite, 17" Soho	110*	B
		6 speed manual	150	17"	110*	18" Oxford Anthracite, 18" Marseille Anthracite	113*	C
	2.0 ltr TDI <a href="#">BMT</a>	6 speed auto DSG	150	17"	121*	16" Sepang, 17" Nivelles Anthracite, 17" Soho	121*	D
		6 speed auto DSG	150	17"	121*	18" Oxford Anthracite, 18" Marseille Anthracite	124*	D
<b>GT</b>	1.6 ltr TDI <a href="#">BMT</a>	6 speed manual	120	18"	110*	18" Marseille Anthracite, 19" Verona	110*	B
	1.6 ltr TDI <a href="#">BMT</a>	7 speed auto DSG	120	18"	107*	18" Marseille Anthracite, 19" Verona	107*	B
	2.0 ltr TDI <a href="#">BMT</a>	6 speed manual	150	18"	113*	18" Marseille Anthracite, 19" Verona	113*	C
	2.0 ltr TDI <a href="#">BMT</a>	6 speed auto DSG	150	18"	124*	18" Marseille Anthracite, 19" Verona	124*	D
	2.0 ltr TDI SCR <a href="#">BMT</a>	6 speed manual	190	18"	111*	18" Marseille Anthracite, 19" Verona	111*	C
	2.0 ltr TDI SCR <a href="#">BMT</a>	6 speed auto DSG	190	18"	120*	18" Marseille Anthracite, 19" Verona	120*	C
	2.0 ltr BiTDI SCR <a href="#">BMT</a> 4MOTION	7 speed auto DSG	240	18"	146*	18" Marseille Anthracite, 19" Verona	146*	F
<b>Alltrack</b>	2.0 ltr TDI SCR <a href="#">BMT</a> 4MOTION	6 speed manual	150	18"	130*	19" Albertville	130*	D
	2.0 ltr TDI SCR <a href="#">BMT</a> 4MOTION	6 speed auto DSG	190	18"	137*	19" Albertville	137*	E
<b>R-Line</b>	2.0 ltr TDI <a href="#">BMT</a>	6 speed manual	150	18"	113*	19" Verona	113*	C
	2.0 ltr TDI <a href="#">BMT</a>	6 speed auto DSG	150	18"	124*	19" Verona	124*	D
	2.0 ltr TDI SCR <a href="#">BMT</a>	6 speed manual	190	18"	111*	19" Verona	111*	C
	2.0 ltr TDI SCR <a href="#">BMT</a>	6 speed auto DSG	190	18"	120*	19" Verona	120*	C
	2.0 ltr BiTDI SCR <a href="#">BMT</a> 4MOTION	7 speed auto DSG	240	18"	146*	19" Verona	146*	F
<b>GTE</b>	1.4 ltr TSI <a href="#">BMT</a> /Electric Motor	6 speed auto DSG	218	18"	40*	18" Marseille Anthracite, 18" Monterrey	40*	A
<b>GTE Advance</b>	1.4 ltr TSI <a href="#">BMT</a> /Electric Motor	6 speed auto DSG	218	18"	40*	18" Marseille Anthracite	40*	A

\* Fuel consumption and CO<sub>2</sub> figures are obtained under standardised EU test conditions (Directive 93/116/EEC). This allows a direct comparison between different manufacturer models but may not represent the actual fuel consumption achieved in 'real world' driving conditions. More information is available on the Volkswagen website at [www.volkswagen.co.uk](http://www.volkswagen.co.uk) and at [www.dft.gov.uk/vca](http://www.dft.gov.uk/vca). Please note: the increase in VED rate that is payable is in addition to the cost of the optional alloy wheels. Please consult your Volkswagen retailer for full details. SCR (Selective Catalytic Reduction) requires AdBlue®, please see page 70 or visit [www.volkswagen.co.uk/technology/adblue](http://www.volkswagen.co.uk/technology/adblue) for more details. [BMT refers to BlueMotion Technology.](#) [BM refers to BlueMotion.](#)

# AdBlue®

Your Volkswagen car is fitted with an advanced emissions control system, which helps your vehicle meet the latest EURO 6 exhaust gas regulations.

## How does the system work?

AdBlue®, a water/urea based additive, is stored in a tank (like diesel fuel), however, unlike fuel it is not injected into the engine, but directly into a specially modified part of the vehicle's exhaust. This begins a chemical reaction which removes the polluting oxides of nitrogen (NOx), converting them into harmless oxygen and nitrogen in a process known as Selective Catalytic Reduction, or SCR for short. SCR is only applicable to diesel engines and the more economically you drive, typically, the less AdBlue® you will use.

The size of the AdBlue® tank fitted to your car will vary depending on which Volkswagen model you have, therefore the interval between top-ups will vary. In addition, many factors such as mileage, journey type, driving style and environmental conditions can influence how much AdBlue® is consumed. A passenger car can consume approximately 1.5 litres of AdBlue® every 620 miles (1.0–1.5 litres for the Passat and Passat Estate). The chart below details the AdBlue® tank size and location.

Model (SCR derivatives only)	Tank size (Approximately)	AdBlue® tank filler location	Initial warning of low AdBlue® (2,400km/1,500 miles to go) can be expected to occur at:
Passat and Passat Estate	13 litres	Next to fuel filler nozzle	4,000 to 6,500 miles or sooner*

\* Distances are approximate and the warning light may come on sooner depending on driving style, journey type, engine and vehicle load and environmental conditions.

## How will I know if the system needs topping-up?

A series of warnings will be given via the driver information system, accompanied by advice/messages.

The first message is displayed when the remaining range is approximately 1,500 miles, and is repeated every 62 miles until the range reaches 1,000 miles, at which point the warning turns amber. This warning is repeated every 31 miles and is accompanied by an audible tone. If these warnings are not acted upon, the warning turns red; once this happens the car will not restart once the ignition is turned off. This is not a fault, but a required feature of the system. If this stage is reached the system will need a full top-up before the car can be restarted. Further information is available in the vehicle handbook.

## Why should I use a Volkswagen Authorised repairer for top-ups?

- AdBlue® top-ups at authorised repairers are extremely competitive and charged by the litre, so you only pay for what you need
- Authorised repairer staff are trained to handle AdBlue®
- AdBlue® tanks need special adaptors on fillers to ensure there are no spillages
- Volkswagen do not recommend keeping top-up bottles in cars

The top-up bottles supplied by Volkswagen have a capacity of 1.89 litres, and come complete with the adaptor nozzles that fit the Volkswagen AdBlue® tank. These are available from all Volkswagen Authorised repairers

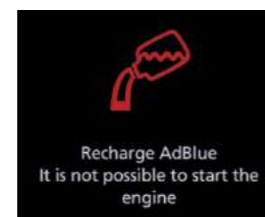
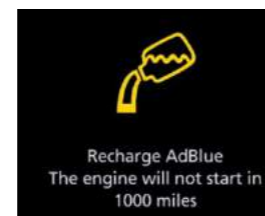

AdBlue® warning lights.

## Important information

- AdBlue® is not a fuel additive. This is why there is a separate AdBlue® tank
- If you put AdBlue® in your fuel tank by mistake, please do not start the engine, but contact a retailer for help
- Put only AdBlue® in the AdBlue® tank; do not fill the AdBlue® tank with any other liquids
- Prevent anything from contaminating AdBlue®
- If small quantities of AdBlue® come into contact with the vehicle's paintwork, for example, wipe them off and if necessary rinse the area with water



Model shown is Passat Estate GT 2.0 BiTDI 240 PS 4MOTION with optional 19" 'Verona' alloy wheels and metallic paint.

---

# The Passat and Passat Estate.



Model shown is Passat GT 2.0 BiTDI 240 PS 4MOTION with optional 19" 'Verona' alloy wheels and metallic paint.

# Volkswagen service.

**Exclusions and terms and conditions apply to all warranties and plans listed. For pricing and further details of Volkswagen Warranties and Service Plans, please consult your authorised Volkswagen retailer or repairer, or visit [www.volkswagen.co.uk](http://www.volkswagen.co.uk)**

## Three-year Warranty

All Volkswagen passenger cars come with a three-year/60,000 miles warranty, which protects your car against the failure of most technical and electrical components due to manufacturing defects. This comprises a two-year manufacturer's warranty with unlimited mileage plus a further one-year/60,000 miles (whichever is soonest) Retailer Warranty<sup>1</sup>. Should the mileage exceed 60,000 miles within the first two years, the manufacturer's two-year warranty will still be valid. Full details of the three-year warranty are available from your authorised Volkswagen retailer or repairer.

## Body Protection Warranty

The internal body sections and panels of the Passat are covered against rusting through from the inside for 12 years. Naturally, the vehicle must be cared for in compliance with the manufacturer's operating instructions. Please consult your authorised Volkswagen retailer or repairer for full warranty details.

## Three-year Paintwork Warranty

This latest paintwork warranty, pioneered by Volkswagen, provides you with cover on a new car. Naturally, during the warranty period the car must be cared for in compliance with the manufacturer's operating instructions. Any paintwork defects, as a result of the manufacturing process, will be rectified without charge.

## Approved Accessories

A comprehensive range of accessories from alloy wheels to carpet mats is available to complement the factory-fitted option list. Volkswagen approved accessories purchased from and fitted by your authorised Volkswagen retailer at the point of vehicle sale will also benefit from the three-year vehicle warranty.

## Extended Warranty

If you order the Volkswagen Extended Warranty as an option when buying your new Passat then you get the 100% Volkswagen Warranty and you can continue to enjoy comprehensive Volkswagen protection against many unforeseeable repair costs. Designed to your needs, you can purchase an extra one or two year's warranty up to a maximum of five years or 90,000 miles.

## Eight-year Battery Warranty (plug-in hybrid models only)

1. A guarantee for eight years or 99,360 miles/160,000km (whichever is soonest), on all material or manufacturing defects.
2. Gradual reduction in battery capacity over times is integral to the nature of the component, and does not represent a defect under the terms of this guarantee, as long as the reduction in capacity is not in excess of the value specified for this vehicle in the owner's manual.
3. The guarantee on high voltage batteries does not apply if the defect has been caused by the battery not being used, handled or maintained as described in the owner's manual. This applies in particular to charging the battery, such as not charging on the CSS (Rapid charge) function 3 times in a row. Please check the owner's manual for more details.
4. With the exception of the warranty term, all warranty conditions stipulated by the Volkswagen retailer selling the vehicle (prerequisites, criteria for freedom from defects, exclusions, settlement of claims, entry into force and start of extended warranty term, scope of application etc.) also apply to the high voltage battery.

## Service Intervals

Volkswagen is pleased to offer you a choice on how your Volkswagen is serviced. The appropriate selection is entirely dependent on how the car is likely to be driven and its general use. To help you identify which type of service would be most suitable, please refer to the following guide.

The Fixed Service is recommended for vehicles that will cover less than 10,000 miles in 12 months and if the vehicle is likely to be used in the following way:

- Predominantly urban driving, short journeys with frequent cold starts.
- Activities regularly producing high engine loading, e.g. frequent hill climbs, driving with vehicle fully loaded and towing.
- Uneconomical driving style using high rpms with heavy acceleration and heavy braking.

The service intervals for the Fixed Service are as follows:

- Oil change service – After 1 year or 10,000 miles (15,000km), whichever is soonest.
- Inspection service<sup>2</sup> – First after 2 years or 20,000 miles (30,000km), then every one year or 20,000 miles (30,000km), whichever is soonest.

The Flexible Service is recommended for vehicles with daily mileage of more than 25 miles where the vehicle is driven regularly mainly on longer distance journeys. The vehicle is driven mainly at a constant speed with minimum vehicle and engine loading, minimal towing and driven in an economical manner. With the Flexible Service the vehicle can cover anywhere between 10,000<sup>3</sup> and a maximum of 20,000<sup>3</sup> miles or 24 months (whichever is soonest) between oil changes.

The service intervals for the Flexible Service are as follows:

- Oil change service – According to flexible service interval display (after 2 years at the latest).
- Inspection service<sup>2</sup> – First after 2 years or 20,000 miles (30,000km), then every one year or 20,000 miles (30,000km), whichever is soonest.

The up! model is only available with the Fixed Service schedule. Please consult your authorised Volkswagen retailer or repairer for advice and full details.

Please note: If you purchase a Volkswagen Fixed Price Service Plan your vehicle will follow the Fixed Service schedule.

## Volkswagen Insurance<sup>4</sup>

We want you to start enjoying your new car from day one and thanks to Volkswagen free 5 day insurance, you can. Call free on 0330 303 6930 (lines are open Monday to Friday 8am – 9pm and Saturday 9am – 5pm), provide a few details and a cover note will be sent to your retailer. They will then tax your car and you can drive it away.

## Volkswagen Ensurance<sup>5</sup>

Get three years' Volkswagen Ensurance cover for free.

Another great benefit of being a Volkswagen driver. If your Volkswagen was damaged in an accident, wouldn't you want it fixed by a Volkswagen trained technician using only genuine Volkswagen parts? Ensurance is Volkswagen's accident and repair cover which does exactly that. It works alongside your main comprehensive motor insurance policy no matter who you are insured with, to make sure you get the quality repair and service you would want. If you're involved in an accident or your car is stolen, just one call to us and we'll look after your claim from start to finish ensuring your Volkswagen is restored to the highest standard.

Activate your cover and benefit from:

- A guarantee that your Volkswagen will be repaired by a Volkswagen approved repairer and Volkswagen trained technicians, using only genuine Volkswagen parts and paints.
- A dedicated Claims Manager who will manage your claim from start to finish, liaising with your insurer and the repairer so you don't have to.
- Help to recover any uninsured losses using our Legal Expenses Cover.
- Online claims tracking so you can keep up to date with the status of any claim.

Volkswagen Ensurance is free to all Volkswagen customers for three years and it only takes a minute to get cover. To find out more and to activate your cover, visit [volkswagen-ensurance.co.uk](http://volkswagen-ensurance.co.uk)

## Volkswagen Finance<sup>6</sup>

Volkswagen Finance specialises in providing funding solutions for Volkswagen drivers. Whether your Volkswagen is for private or business use, you can choose from a range of funding options.

- Solutions – a Personal Contract Plan
- Hire purchase
- Lease purchase
- Finance lease
- Contract hire

With all Volkswagen Finance products you can choose a fixed-cost maintenance plan to help you budget for your servicing and maintenance costs. No matter what finance product you choose, your local Volkswagen retailer will be able to provide you with a personalised quote that could meet your budget and vehicle needs.

## Fuel consumption and CO<sub>2</sub> Emissions

Fuel consumption and CO<sub>2</sub> figures are obtained under standardised EU test conditions (Directive 93/116/EEC). This allows a direct comparison between different manufacturer models but may not represent the actual fuel consumption achieved in 'real world' driving conditions. More information is available on the Volkswagen website at [www.volkswagen.co.uk](http://www.volkswagen.co.uk) and at [www.dft.gov.uk/vca](http://www.dft.gov.uk/vca).

The weight of a vehicle will influence the level of CO<sub>2</sub> emissions it produces; as a result, vehicles with higher levels of specification and factory-fitted options may emit higher levels of CO<sub>2</sub>. Choosing larger alloy wheels than those fitted as standard may result in increased fuel consumption as well as higher CO<sub>2</sub> emissions and subsequently an increased Vehicle Excise Duty (VED) band. BIK rates paid by company car drivers may also increase. In some instances, the recommended 'On the road' retail price paid for a vehicle may increase as a result of the increased VED rate. CO<sub>2</sub> is the main greenhouse gas responsible for global warming. The specifications contained in this brochure are for information purposes only and are subject to change.

## AdBlue<sup>®</sup>

Diesel engines with SCR (Selective Catalytic Reduction) technology require AdBlue<sup>®</sup> which must be kept topped up. Please see page 70 or visit [www.volkswagen.co.uk/technology/adblue](http://www.volkswagen.co.uk/technology/adblue) for more details.

## Volkswagen Roadside Assistance

Every new car is registered for Volkswagen Roadside Assistance for one year except the Touareg and Phaeton which are registered for three years. This provides vehicle roadside and home recovery in the unlikely event of a breakdown in the UK and Europe (subject to conditions). Volkswagen Roadside Assistance can also be purchased for subsequent years. For full details, please contact your authorised Volkswagen retailer. Exclusions and terms and conditions apply. For pricing and further details of Volkswagen Roadside Assistance, please consult your authorised Volkswagen retailer, or visit [www.volkswagen.co.uk](http://www.volkswagen.co.uk)

## Tax Free Sales

For full details, please contact your authorised Volkswagen retailer.

## Please note:

Some illustrations in this brochure do not necessarily reflect UK specifications and may not be available. In particular, controls and some items of equipment are positioned differently for the UK. The specifications contained in this brochure are for information purposes only and are subject to change. If you require any specific feature, you must consult your authorised Volkswagen retailer who is regularly updated with any change in specification. Please check model availability and full specification details with your authorised Volkswagen retailer prior to ordering. Note: we would like to advise you that telephone calls to Volkswagen Customer Care may be monitored and recorded as part of our training and quality assurance processes. All our monitoring and recording processes meet Ofcom regulations.

<sup>5</sup> Ensurance from Volkswagen Financial Services is sold and administered by Lawshield UK Limited, registered in England number: 3360532 (registered office: Lawshield House, 850 Ibis Court, Lakeside Drive, Centre Park, Warrington, Cheshire WA1 1RL) and underwritten by UK General Insurance Limited on behalf of Ageas Insurance Limited, registered in England number: 354568 (registered office: Ageas House, Tollgate, Eastleigh, Hampshire SO53 3YA).

<sup>6</sup> Finance is available to 18s and over, subject to status. Terms and conditions apply. Volkswagen Finance.

# The Passat and Passat Estate

Volkswagen Information Service. Telephone: 0800 333 666

Internet: [www.volkswagen.co.uk](http://www.volkswagen.co.uk)

© Volkswagen Group United Kingdom Limited 2016.

Issue: 21 December 2016.



[facebook.com/VolkswagenUK](https://facebook.com/VolkswagenUK)



[@UKVolkswagen](https://twitter.com/@UKVolkswagen)



[youtube.com/user/ukvolkswagen](https://youtube.com/user/ukvolkswagen)